

Call Recorder Single Digital Manual

V2.2

VC2003



Vidicode

Blauw-roodlaan 140
2718 SK Zoetermeer
The Netherlands

Phone

+31(0)79 3617181

Fax

+31(0)79 3618092

Sales

+31(0)79 3471010

Support

+31(0)79 3471005

vidicode

Email

vidicode@vidicode.nl

Internet

www.vidicode.nl

The Call Recorder Single Digital

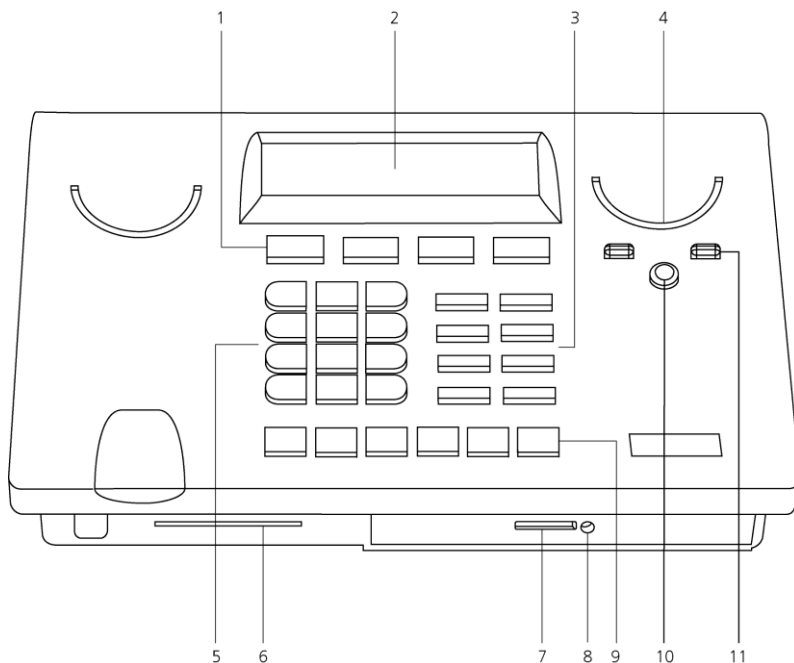

1. Soft keys
2. Display
3. Function keys
4. Speaker
5. Alfa-Numerical keys
6. CryptoCard reader
7. SD card slot
8. SD card in use LED
9. Recorder keys
10. Speaker on/off
11. Volume control

Connections Call Recorder Single Digital

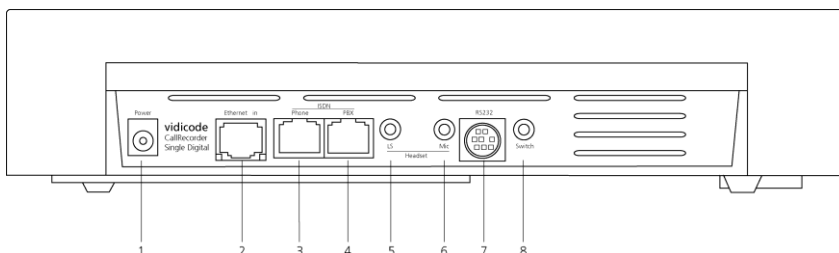

1. Power
2. Ethernet / LAN
3. RJ45 and RJ11: 2/4 wire digital out (= to Phone / ISDN NT)
4. RJ45 and RJ11: 2/4 wire digital in (= from PBX / ISDN TE) *
5. Loudspeaker
6. Microphone
7. RS-232 for maintenance
8. Switch input

* When using ISDN, use a cable less than 50meter for this connection.

Recorder-keys

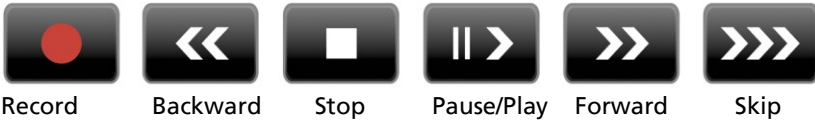

During recording and playback the recorder keys have the standard recorder key functions.







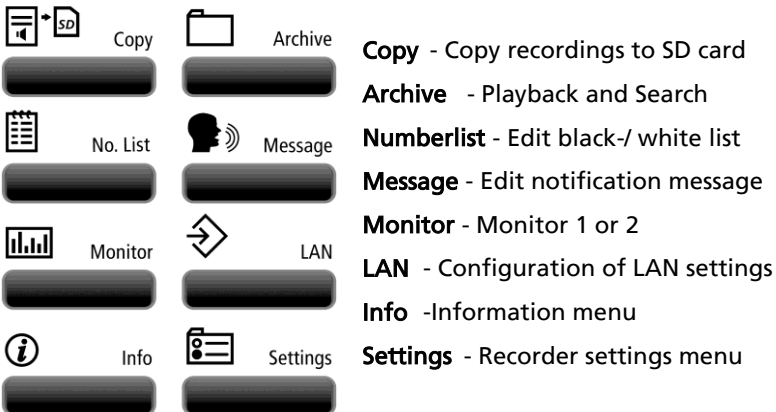



If no recording or playback is taking place these keys have a different function. The and keys can be used to scroll through a selection of recordings, numbers in a list or through a settings menu. The key will always exit the current operation. When editing text they function as explained in the table of the alpha-numerical functions below.

In normal operating mode, when no recording is taking place, pressing the key will temporarily brighten the LCD background lightening.





Function-keys desktop model



Alfa-numerical functions

| Numerical keys | Function | | | | |
|---|---|----|----|----|----|
| | Press the relevant key repeatedly or hold down: | | | | |
| | 1x | 2x | 3x | 4x | 5x |
|  | 1 | . | : | ' | ; |
|  | A | B | C | 2 | ! |
|  | D | E | F | 3 | % |
|  | G | H | I | 4 | ^ |
|  | J | K | L | 5 | \$ |
|  | M | N | O | 6 | @ |
|  | P | Q | R | 7 | 7 |
|  | T | U | V | 8 | & |
|  | W | X | Y | Z | 9 |
|  | * | @ | / | < | > |
|  | 0 | _ | + | - | = |
|  | # | (|) | [|] |
| Recorder keys | Function | | | | |
|  | Toggle uppercase and lowercase | | | | |
|  | Forward | | | | |
|  | Backward | | | | |

Care and Maintenance

| | |
|---|--|
|  | <p>Keep the Call Recorder dry. If it gets wet, wipe it dry immediately. Liquids might contain minerals that can corrode the electronic circuits.</p> |
|  | <p>Use and store the Call Recorder only in normal temperature environments. Temperature extremes can shorten the life of electronic devices and distort or melt plastic parts.</p> |
|  | <p>Keep the Call Recorder away from excessive dust and dirt that can cause premature wear of parts.</p> |
|  | <p>Do not use harsh chemicals, cleaning solvents or strong detergents to clean the Call Recorder.</p> |

Contents

| | |
|--|----|
| 1. Introduction | 11 |
| 1.1 Basic Functions | 11 |
| 1.2 Speech Compression | 12 |
| 1.3 Network | 12 |
| 1.4 Search recordings | 12 |
| 1.5 Encryption | 12 |
| 1.6 Digital telephone connection | 13 |
| 1.7 Privacy related functions | 13 |
| 2 The Call Recorder Single Digital | 15 |
| 2.1 What's in the box | 15 |
| 2.2 Connecting the Power supply | 15 |
| 2.3 Connecting the digital lines | 16 |
| 2.3.1 Connecting to a single telephone | 16 |
| 2.3.2 Connecting to a Basic Rate ISDN line | 17 |
| 3 Configuration and operation | 18 |
| 3.1 Operation basics | 18 |
| 3.2 Frequently used key indicators | 19 |
| 3.3 Save Changes | 19 |
| 4 Recorder Settings | 20 |
| 4.1 Opening the Recorder settings menu | 20 |
| 4.2 Line interface | 20 |
| 4.3 Start method | 20 |
| 4.4 Protocol | 21 |
| 4.5 Audio Detect Settings | 22 |
| 4.6 Audio start side | 23 |
| 4.7 Silence period | 24 |
| 4.8 In-Line mode | 24 |
| 4.9 Notification | 25 |
| 4.10 Numberlist | 26 |
| 4.11 Compression | 26 |

| | | |
|--------|--|----|
| 4.12 | Minimum Call time | 27 |
| 4.13 | Copy to SD | 27 |
| 4.14 | CryptoCard | 28 |
| 4.15 | Password | 28 |
| 4.15.1 | Remove Password protection | 29 |
| 4.16 | Set the Clock | 29 |
| 4.17 | Language | 30 |
| 4.18 | Factory settings | 30 |
| 5 | Archive menu playback and search | 32 |
| 5.1 | Playing the last recorded call | 32 |
| 5.2 | Search stored recordings | 33 |
| 5.2.1 | Search according to Local number | 34 |
| 5.2.2 | Search according to Remote number | 35 |
| 5.2.3 | Search according to Connected number | 35 |
| 5.3 | Recording information | 36 |
| 5.4 | Erase a recording from the drive | 37 |
| 6 | Copy recordings to SD card | 38 |
| 6.1 | Copy the last recording to SD card | 38 |
| 6.2 | Copy a selection of recordings | 38 |
| 6.3 | Copy an individual recording during playback | 39 |
| 6.4 | Copy a selection of recordings (alternative) | 40 |
| 7 | Numberlist | 41 |
| 7.1 | View the Blacklist or Whitelist | 41 |
| 7.2 | Add a number to the list | 41 |
| 7.3 | Remove a number from the list | 42 |
| 8 | Notification message | 43 |
| 8.1 | Record notification message | 43 |
| 9 | Monitoring | 45 |
| 9.1 | Monitoring on the desktop model | 45 |
| 10 | The Information menu | 46 |

| | | |
|-------|---|----|
| 11 | LAN Settings | 48 |
| 11.1 | Network active | 48 |
| 11.2 | FTP active | 49 |
| 11.3 | FTP user | 49 |
| 11.4 | FTP password | 49 |
| 11.5 | FTP server port | 50 |
| 11.6 | DHCP server | 51 |
| 11.7 | IP address | 51 |
| 11.8 | IP subnet mask | 52 |
| 11.9 | Gateway | 52 |
| 11.10 | IP name | 53 |
| 11.11 | E-mail | 53 |
| 11.12 | Reply address | 54 |
| 11.13 | SMTP server IP address | 54 |
| 11.14 | SMTP server port | 55 |
| 11.15 | Domain name | 55 |
| 11.16 | DNS server | 56 |
| 11.17 | NTP server | 57 |
| 11.18 | NTP port | 57 |
| 11.19 | GMT correction | 58 |
| 11.20 | Telnet | 58 |
| 11.21 | Service timer | 59 |
| 11.22 | Monitor active | 59 |
| 12 | Encrypted recording | 61 |
| 12.1 | Several types of CryptoCard | 61 |
| 12.2 | Insert a CryptoCard into the recorder | 62 |
| 12.3 | The CryptoCard and its PIN and PUC code | 62 |
| 12.4 | Making an encrypted recording | 63 |
| 12.5 | Playing an encrypted recording | 64 |
| 12.6 | Using CryptoCards on a PC | 64 |
| 13 | Acknowledgements | 65 |
| 13.1 | Privacy | 65 |
| 13.2 | Guarantee | 65 |

| | | |
|------|-----------|----|
| 13.3 | Liability | 66 |
| 14 | Index | 67 |

1. Introduction

The Call Recorder Single Digital is a digital audio recorder for two-wire (Up0) or four-wire (S0) telephony.

IMPORTANT!

The Call Recorder Single Digital has an SD Card interface and a network interface. The SD Card interface may be activated 'off factory', if not, it is possible to activate it anytime, using the activation card, which is part of the SD option. The SD option also contains the actual SD card and the Quick SD access software.

This manual is written for the Call Recorder Single Digital with the SD card option activated. If you purchased a Single Digital without SD card option, the 'Copy to SD' button will not work and the option SD-CARD will not be visible in the display.

1.1 Basic Functions

The Call Recorder Single Digital is designed for continuous unattended recording. All recordings are stored digitally on the internal Compact Flash Card (Solid-State Drive). The large storage capacity of the Compact Flash Card ensures the ability of long term unattended recording. Recordings are randomly accessible. The capacity of a (16GB) Compact Flash Card is in recording time at least 500 hours uncompressed and 2500 hours with compression, and therefore it takes a long time before existing recordings are wiped out by new recordings. When the drive is getting full, the oldest recordings will be overwritten by the newest (first in first out archive).

The available space on the drive is shown in the Information menu. Stored recordings can also be accessed on PC's via the LAN using the optional Call Recorder Access System software. Using the LAN and this software is the best way to backup all your recordings.

If you have a Call Recorder Single Digital with an activated SD interface, you can copy recordings from the internal drive to a removable SD card. Copying recordings to SD card is ment to be used in the case one or more important recordings must be transferred in a fast and easy way. It is possible to copy single recordings or copy a selection of recordings. The Single Digital allows the user to listen to ongoing calls through the internal speaker; this is called the Monitor function. The volume of the internal speaker can be adjusted. The Single Digital also allows for the connection of a headset. The headset can be used to monitor ongoing calls and to listen to stored recordings.

1.2 Speech Compression

The Single Digital compresses recordings according to the GSM 6.10 format. GSM 6.10 compression has a good balance between audio quality and recording size and can be reproduced on most PC's with Microsoft Windows versions. Compressed recordings take up 1/5 of the size of uncompressed recordings. Therefore the compression has a profound effect on the storage capacity of the recorder in terms of recording time.

1.3 Network

The Call Recorder Single Digital features an Ethernet interface. The Single Digital can be connected to a PC or computer network through the Ethernet interface. With its own IP address The Single Digital acts as an FTP-server from which recordings can be downloaded using any FTP client. The Call Recorder Access System software can be used to connect to the Call Recorder Single Digital over the network to retrieve recordings and archive them on the PC. The Call Recorder Access System software has extensive archiving capabilities including the creation of special archives suited for backup on CD.

The Single Digital can email its status in case of a malfunction. To do so, the e-mail address and SMTP server address must be entered in the Network Settings menu.

Another application of the Ethernet connection is Real Time Remote Call monitoring over the network. The optional RTR Call Monitor software can be used to monitor the connected telephone line over the network and provides live call listening while the call is in progress.

1.4 Search recordings

The Call Recorder Single Digital has its own menu driven search function to find and play specific recordings. Recordings can be searched for according to date or phone number. The Single Digital has an internal speaker for playback of internally stored recordings.

1.5 Encryption

All recordings can be encrypted. The Call Recorder Single Digital uses the CryptoCard option for this feature. Playback of encrypted recordings is not possible without the CryptoCard the recording was made with. Playback of encrypted recordings on a PC is possible only with the

optional CryptoCard reader in conjunction with the original or a matching CryptoCard.

1.6 Digital telephone connection

The Call Recorder Single Digital can be connected to two types of digital telephony, ISDN (S0 or S/T interface) or two-wire digital telephony (Up0 interface). In both situations they are connected in “pass through mode” meaning that the recorder is installed between the network and the telephone system and all digital channels pass through the recorder. Pass Through mode is also occasionally called “In-Line mode”. Connecting the recorder in this way has the advantage that it is assured an ongoing call is recorded; the line is passing the recorder and if that fails the phone won’t work.

Note: The ISDN connectors (connectors 3 and 4 of page 4) are specially adapted for this purpose. They can not only take RJ-45 ISDN connectors, but can also accept the RJ-11 connectors used in typical two-wire digital telephony systems.

1.7 Privacy related functions

In some situations Call Recording is perceived as an intrusion of the privacy. The Call Recorder Single Digital has several functions that allow the user to protect the privacy of anyone involved.

In most applications the recorder is set up to record all calls automatically. The Single Digital can however be used to record specific numbers only or can be set to exclude certain numbers from recording. For this feature the recorder has a numberlist that can be used as “blacklist” or as “whitelist”. See Chapter 8 for more details.

The Single Digital can be used as a security recorder. For this purpose the recorder has a feature where the number of day’s can be set for the recorder to keep the recordings (in the settings menu this function is called Auto Delete). In case of an emergency, recordings can be accessed while daily recordings are removed after the set number of days. This is used when for matters of privacy it is not desirable to keep recordings of the people involved for a long period. See § 4 for details.

The CryptoCard option can be very effective to protect privacy. When the Single Digital is set up to record with the CryptoCard the privacy of the people involved can be guaranteed because the recordings can only be played with a card matching the card the recording was made with and the password that belongs to it. Without the CryptoCards the recordings are not accessible. There are CryptoCards that can only be

used to encode and not to decode recordings, so even when the recorder is stolen the privacy of its users remains protected.

2 The Call Recorder Single Digital

2.1 What's in the box

The following parts are supplied with your Call Recorder Single Digital:

- Single Digital
- Mains power supply adapter and cable
- A cable with two RJ45 connectors (2 meter)
- A cables with two RJ11 connectors (30 centimeters)
- Quick Install Guide
- Application CD
- Registration / Guarantee form

2.2 Connecting the Power supply

The Call Recorder Single Digital is powered through an AC power adapter. It does not have an On/Off switch; The Single Digital is turned on or off by connecting or disconnecting the power supply.

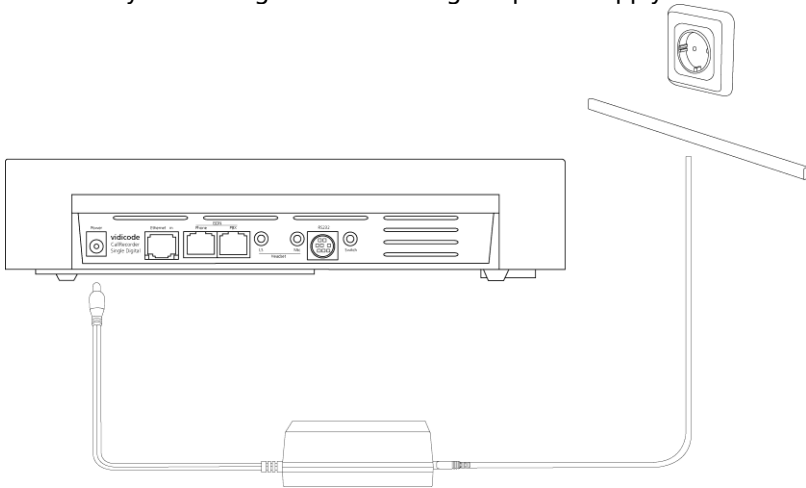

2.3 Connecting the digital lines

As explained in the introduction, the Call Recorder Single Digital works in pass through mode where it is processing the complete data stream. The figure below is an example of a possible setup of the recorder.

2.3.1 Connecting to a single telephone

Most often the Single Digital will be used to record conversations of just one single telephone, and be placed on the same desktop as the telephone. This must be a telephone that operates on a digital line. It doesn't matter if the telephone is using a four-wire (S0) protocol or a two-wire digital telephony (Up0) protocol, in both cases the Single Digital is connected in the same way. The line coming from your PBX is plugged into the PBX connector (4 of page 4), and the Phone connector (3 of page 4) is connected to your digital telephone.

Connectors 3 and 4 accept both S0 (RJ-45) and Up0 (RJ-11) connectors. Because the electrical interface is different the Single Digital must first be configured for the correct interface setting, see § 0. If you connect the wires the wrong way the Single Digital will periodically emit beeps displaying the message "Line disconnected!".

If the Single Digital is turned off, the telephone is turned off as well.

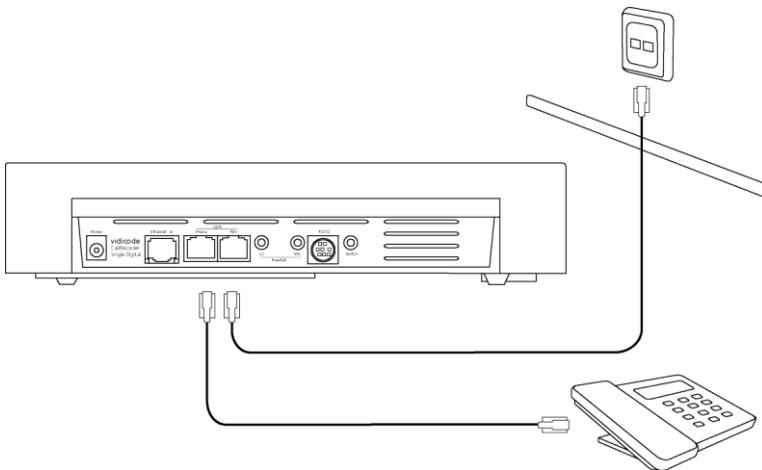

When using a two-wire digital Up0 or the four-wire S0 system, several protocols could be in use. If you configure the wrong protocol your telephone might still work but the conversations might not be recorded.

Note: The Single Digital is only compatible with two-wire digital telephones that adhere to the Up0 standard.

2.3.2 Connecting to a Basic Rate ISDN line

Where the recorder is used as an ISDN recorder and placed in between the ISDN line (NT) and the ISDN PBX (TE), it is recording all incoming and outgoing traffic. The line coming from the ISDN network provider is plugged into the PBX connector (4 of page 4), and the ISDN PBX or telephone is connected to the Phone connector (3 of page 4). Normally an ISDN line uses RJ-45 connectors.

Also note that in all operating modes the line is terminated with 100 Ohm resistors, except for the TE input in ISDN (S0) mode. The TE input is designed for a short, (less than 50 meters) point to point connection, and therefore is not terminated. If you want to use a longer cable, or point to multipoint connection, you may want to add your own terminating resistors, between pins 4 and 5, and 3 and 6 of the ISDN connector. In Up0 mode all connections are terminated.

The figure below is an example of a possible setup of the Call Recorder Single Digital on a Basic Rate ISDN line.

Note that although a PABX is connected, it is still connected to the "phone" ISDN output connector, while the "PBX" input connector is connected to the ISDN NT1 adapter (with a short cable).

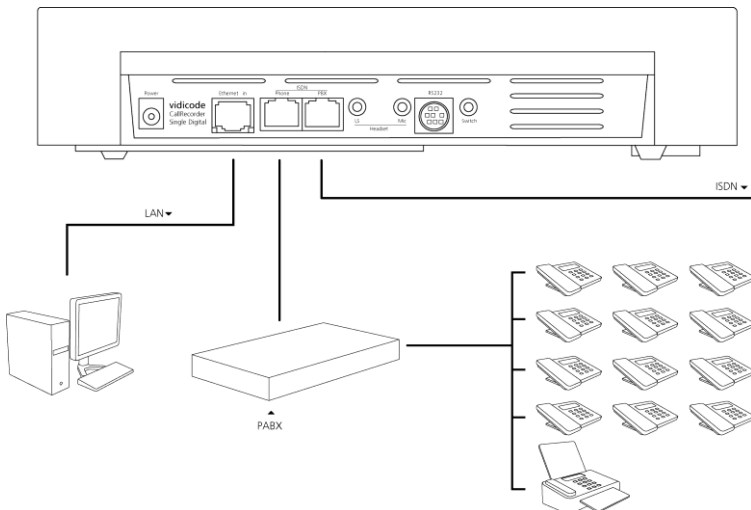

3 Configuration and operation

After you have connected the hardware it is time to configure and use the Call Recorder Single Digital. This chapter explains you how the user interface works. In the following chapters we guide you with the configuration. You must:

- Go through the recorder settings and make changes if required
- Go through the LAN settings so the recorder will fit in with your network
- (Optional) Install the Call Recorder Access System software on your PC and test the network connection to the recorder

3.1 Operation basics

The Call Recorder Single Digital has a common menu driven user interface. Most functions and operations are initiated by pressing a function key followed by a sequence of menu keys of which the function is determined by the text in the display. The use of function keys and menu keys is as follows:

Function keys

The most frequently used functions of the Single Digital have been grouped in the function keys. Throughout the entire manual symbols representing the function keys are used to indicate the function key corresponding to the described function.

Menu keys

After pressing a function key the available functions are assigned to the four menu keys. The operation of the menu keys is determined by the text in the display right above the corresponding key. Throughout the entire manual figures representing the display with or without the menu keys are used to show the required action corresponding to the described feature.

Example:

In this example we will open the recorder settings menu. Press the "Settings function key",  to open the Recorder setting menu.

The display will change, and text will appear on the display above four Soft keys.

These indicate the function that the softkey below has, for example pressing the **STOP** key will cancel the recorder settings menu, to return to operating mode.



3.2 Frequently used key indicators

NEXT in the display indicates the presence of more menu items. Press **NEXT** to jump to the following menu item.

BACK in the display indicates the presence of an embracing menu. Press **BACK** to return to the embracing menu.

CHANGE will toggle the item in the display between "On" and "Off". In some cases **CHANGE** is used to increase or decrease a value.

STOP in the display indicates the absence of an embracing menu. Press **STOP** to return to operating mode.

3.3 Save Changes

After changing the settings press **STOP** in the menu and

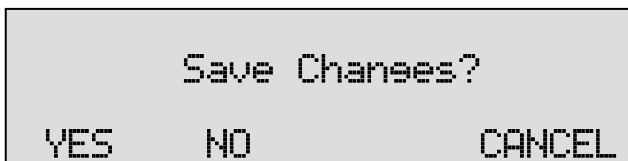

- Press **YES** to returns to normal use with changed settings
- Press **NO** to return to normal use without changed settings
- Press **CANCEL** to return to the settings

4 Recorder Settings

Recorder settings of the Call Recorder Single Digital consist of the following configuration items: Interface, Start method, Protocol, Notification, Numberlist, Compression, CryptoCard, Password, setting of the Clock, LCD contrast, setting the Language and resetting to Factory setting.

4.1 Opening the Recorder settings menu



- Press the  Settings key to enter the recorder settings menu.

4.2 Line interface

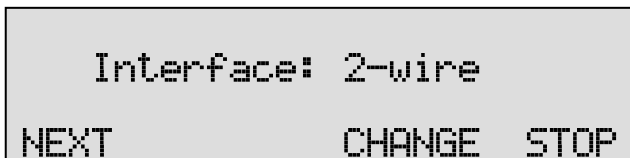
The first item in the settings to appear is the line interface setting. In most cases the interface must be set to 2-wire. Only in the case of ISDN and the Philips D325-4 line, the interface must be set to 4-wire.



```
Interface: 2-wire
NEXT          CHANGE  STOP
```

- Press **CHANGE** to switch from 2-wire to 4-wire.
- Press **NEXT** or the  and  recorder keys to step through the settings menu.

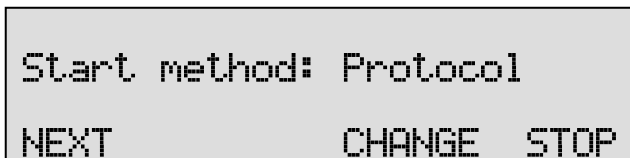

4.3 Start method

The start method defines the way the recordings are started and stopped.



```
Start method: Protocol
NEXT          CHANGE  STOP
```

There are 4 start methods:

1. **Protocol** - Uses the inherent protocol in the digital signal to start and stop the recording when the protocol signals a conversation is going on.
 2. **Audio** - Doesn't use the protocol, but looks if the audio channels are in use, and starts the recording when there is audio to record. The recording is stopped again after some period of silence. This works even when the protocol is unknown, or unsupported.
 3. **Switch** - Uses an external switch to start a recording. This can be a "big red switch", a relay contact of the digital audio source, or an "off-hook switch" of some kind.
 4. **Manually** - uses the red recording button on the recorder to start a recording, so the user can decide if and when recording takes place, instead of recording everything. The square stop button stops the recording again.
- Press **CHANGE** to select the Start method of your choice.
 - Press **NEXT** or the  and  recorder keys to step through the settings menu.

4.4 Protocol

In case the start method has been set to Protocol the next menu item will be the protocol selection.

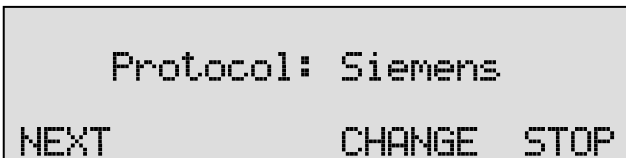

Which Protocol to choose depends on the make of the telephone and PBX. The Single Digital supports four protocols at the moment: Siemens, Avaya, Philips and ISDN.

- Press **CHANGE** to select the Protocol of your choice.
- Press **NEXT** to go to the Notification.

NOTE 1 : In case ISDN is selected as the protocol, the recorder is capable of recording two calls at the same time, started and stopped by the ISDN protocol. With other protocols this is not possible. Only when the Start

method is set to Audio the recorder can recognize a call on the second line/channel and therefore record two calls simultaneously.

Note 2 : A four-wire (S0) system will generally use the standard ISDN protocol, although sometimes the Philips protocol can be used. For two-wire (Up0) systems any of these protocol can be used, ask the manufacturer of your Up0 telephone system for details about the protocol used if you do not know. If you use the wrong protocol the Single Digital will not start recording and/or your telephone does not work.

4.5 Audio Detect Settings

This setting concerns the level of the signal above which the recorder will automatically start to record. Only when the Start method has been set to Audio, the following is shown in the display:



To set this select **CHANGE** and the signal level measure will appear on the display:

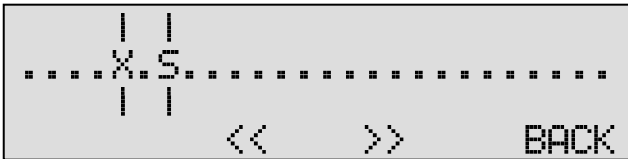

Any signal made now will be graphically represented:



A signal beyond the 'S' is sufficient to start a recording. So, the 'S' indicates the minimum signal level necessary for recordings to start. The

'X' indicates the stop level. Recording stops again when the signal stays below the 'X' for a certain time (manufacturer's setting is 10 seconds; see Silence period below). Normally the stop level will be lower than the start level, so that recording will take place even if somebody speaks in a low voice.

Below is a table with the functions at your disposal when setting the signal level:

| Key | Function |
|-----------------|---|
| Soft keys << >> | Move the start level, indicated by 'S' |
| ⏪ ⏩ | Move the stop level, indicated by 'X' |
| ◻ | Same as BACK |
| ⏸ | Shows the levels in numbers (keep pressed) |
| Speaker key | Listen to audio on the line (toggle speaker on/off) |
| 1, 2 | Switch to line (channel) 1 or 2 |
| 4, 5, 6 | Show Remote, Local, Mixed level only |

4.6 Audio start side

This setting only appears when the Start method has been set to Audio:

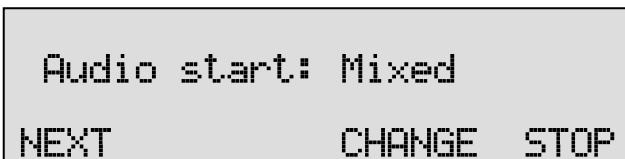

- Press **CHANGE** to select Local, Remote or Mixed.

The recorder looks at the start level to start a recording. This level can be taken from the local side only, the remote side only or the mixed sides (local+remote).

In practice the remote side is normally the speaker of the handset on your telephone. Then the local side is the microphone of the handset. In most cases there is no need to change this setting.

NOTE: If recordings are started when no call is going on, so the handset is on-hook, it is probably needed to set the start level on the remote side only. This means that the microphone of the handset or headset is always open and producing audio.

4.7 Silence period

This setting only appears when the Start method has been set to Audio:

```
Silence Period: 10s
NEXT      - CHANGE +      STOP
```

This is the period during which the sound has to be below the level set on the signal level meter to stop recording. The period can be increased when a recording is often switched off, and then restarted, if nothing is being said for a longer period of time during a conversation.

- Press **CHANGE +/-** to increase or decrease the silence period.
- Press **NEXT** to go to the Notification.

4.8 In-Line mode

Important setting that controls the way the line is connected, also called 'Pass-Through Mode'.

If set to **Yes**, the recorder is connected in series with the phone and PBX. This is the safest way to connect if recording is a must. The phone does not work anymore when the recorder is powered off or the line is disconnected.

If set to **No**, the recorder must be connected parallel to the line: Two normal T-connectors are needed (1:1). The phone/PBX signal on the first one and also to the second T-connector. The second one must be connected to both recorder inputs.

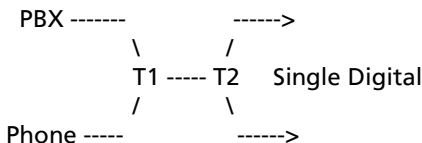

In this 'sniff' mode, the recorder can be disconnected without the user noticing this.

Powering off the recorder may or may not be noticed, depending on the PBX and phone system.

Disconnecting the line while the recorder is active still gives an error (warning beeps).

Note1: When connecting the Single Digital to the line in this mode, synchronization to the phone and PBX must be found. This procedure disturbs the working of the phone for a short while with intervals of about 10 seconds, until the recorder is synchronized. This usually takes less than 1 minute.

Note2: The notification message is not available anymore when In-Line mode is disabled!

```
In-Line mode:  Yes
NEXT          CHANGE  STOP
```

- Press - or + to alter the line input amplification.
- Press **NEXT** to continue in the menu or press **STOP** to exit the settings menu.

4.9 Notification

In some countries or regions notification during the recording of telephone conversations is obligatory. Check local regulations and obligations.

Notification can be with a spoken message at the beginning of the call or at the moment the recording is started. A notification message could be for example: "For security reasons our calls are being recorded". Following the Protocol setting as described above

```
Notification:  Off
NEXT          CHANGE  STOP
```

- Press **CHANGE** to set the Notification method to Incoming, Outgoing, Always or Off.

These options work as follows:

When "**Incoming**" is selected the message will only be played when an incoming call is answered.

When "**Outgoing**" is selected the message will only be played when an outgoing call is answered.

When "**Always**" is selected the message is played on both incoming and outgoing calls.

When "**Off**" is selected there is no notification. This is the default setting.

Please refer to § 8.1 how to record the notification message.

4.10 Numberlist

The Numberlist is used to include or exclude calls from or to certain telephone numbers from recording. See the description of the Numberlist in Chapter 7. The setting Numberlist determines whether the Numberlist is used as "blacklist" or "whitelist" or whether it is turned "Off". By default the number list is "Off".

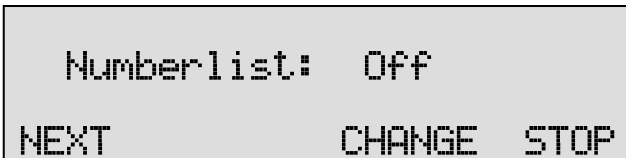

- Press **CHANGE** to select Off, Blacklist or Whitelist.
- Press **NEXT** to continue in the menu with the Compression.

4.11 Compression

The default procedure while recording is to compress the recorded audio from G.711 aLaw to GSM 6.10. This is a factor 5 compression with hardly any loss of quality. It can however be disabled. The available recording time on the Compact Flash card is calculated based on GSM 6.10 compression.

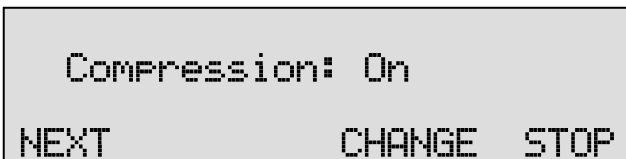

- Press **CHANGE** to enable or disable compression.
- Press **NEXT** to continue with the Minimum Call Time.

We recommend keeping compression enabled with some exceptions: If you record only occasionally, one may consider that compression is not necessary because the hours of recording time that last without compression are sufficient and you do not want the loss of quality.

However, if you consider disabling compression, we recommend that at least the quality of compressed audio is tested. It may change your mind because the quality of compressed recordings is quite good.

4.12 Minimum Call time

By default the Min. Call time will be set to 3 seconds. This means that a call shorter than 3 seconds will not be recorded.

```
Min. Call time: 3s
NEXT      - CHANGE +      STOP
```

- Press **CHANGE +/-** to increase or decrease the minimum time.
- Press **NEXT** to continue with the Crypto Card setting.

4.13 Copy to SD

If you have a Call Recorder Single Digital with the SD-card interface activated, each recording can be copied automatically to SD-Card. This is done directly as soon as a call has finished. In the case a copy action is not finished and a reset or power down happens, the recorder does not memorize the recording for copy. In that case a manual copy must be started.

```
Copy to SD: No
NEXT          CHANGE  STOP
```

- Press - or + to alter the line input amplification.
- Press **NEXT** to continue in the menu or press **STOP** to exit the settings menu.

4.14 CryptoCard

The CryptoCard is used for encrypting recordings. See Chapter 12 for a detailed description. In the standard configuration the CryptoCard function is disabled. With the CryptoCard function enabled all recordings will be encrypted and it is no longer possible to make recordings without a CryptoCard.

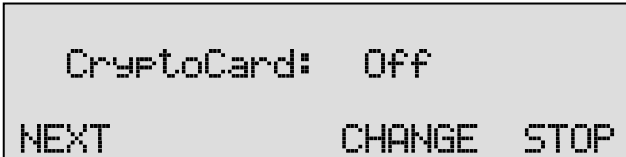

```
CryptoCard:  Off
NEXT          CHANGE  STOP
```

- Press **CHANGE** to enable or disable the CryptoCard function.

When the CryptoCard function is enabled and there is no card inserted the Call Recorder will sound a warning and display:

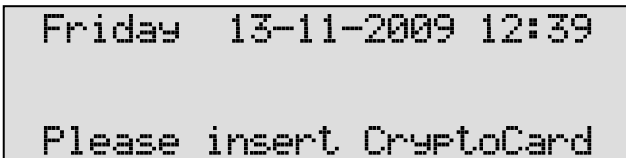

```
Friday 13-11-2009 12:39
Please insert CryptoCard
```

The warning will disappear when a valid card is inserted.

- Press **NEXT** to continue with the Password.

4.15 Password

The Call Recorder Single Digital and its recordings can be protected with a password against unauthorized use. When password protection has been enabled all recorder settings and all playback functions are blocked before the correct password has been entered.

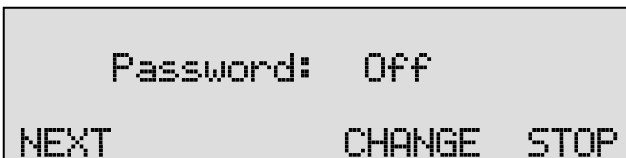

```
Password:  Off
NEXT          CHANGE  STOP
```

- Press **CHANGE** to enable the password.
- You will be prompted to enter a new password:

```
New Code: █
STORE                CANCEL
```

- Press **STORE**.
- You will be prompted to enter the password again:

```
Repeat Code: █
STORE                CANCEL
```

- Repeat the new password.
- Press **STORE** to finally enable the new password.

If the Password has been set you will be prompted for the password before entering the menus and before playback of recordings.

4.15.1 Remove Password protection

```
Password: On
NEXT          CHANGE  STOP
```

- Press **CHANGE** to disable the password.
- Press **NEXT** to continue in the menu with the **Clock** setting.

4.16 Set the Clock

To set the clock do the following:

```
Clock: Fri 10-07-09 12:39
NEXT          CHANGE  STOP
```

- Press **CHANGE** to change the setting of the clock.

```
Clock: Fri 10-07-09 12:39
STORE  <  >  CANCEL
```

- Press key's 1-7 to set the day of the week (Sunday is 1). Use the arrowed keys to move the blinking character left or right.

The default date and time format is DD-MM-YY and MM:HH. When American has been set as the language the format is changed to MM-DD-YY.

- Press **STORE** to store the changes and set the clock.
- Press **CANCEL** to return to previous values.
- Press **NEXT** to continue with the LCD Contrast setting.

4.17 Language

To set your preferred language:

```
Language: English
NEXT      CHANGE  STOP
```

- Press **CHANGE** multiple times to select the preferred language.
- Press **NEXT** to go to the last menu item.

4.18 Factory settings

It is possible to reset all settings to factory defaults at once. To return to the original settings:

```
Factory settings: No
                  CHANGE  STOP
```

- Press **CHANGE** and then **STOP** to reset all settings.
- The system asks you to confirm the changes made.

Save Changes?

YES

NO

CANCEL

- **YES** returns to normal use with changed settings.
- **NO** returns to normal use without changes.
- **CANCEL** continuous with the settings.

5 Archive menu playback and search

All stored recordings can be played back on the recorder. To play a certain recording it has to be found and selected first. To find a recording the Call Recorder has a search function. The search function is described in § 5.2.

The Call Recorder also has a simpler and faster way to play the last recorded call. Playback of a selected recording is done with the recorder keys; it is the same as playback of the last recording as described in the following paragraph.

5.1 Playing the last recorded call

- Press the  key or the  key to open the playback menu.

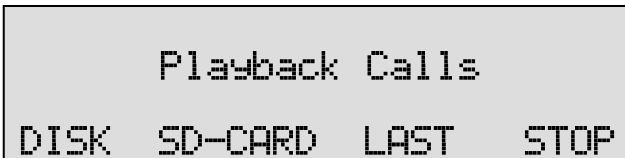

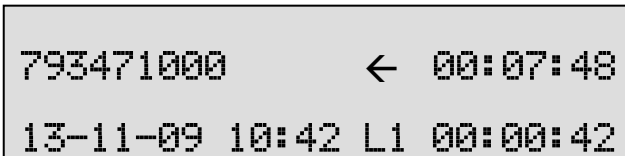

- Press **LAST** or the  key again to play the last recording:



Playback of the last call will start immediately.

The display shows the remote number, if available. Next to that is the duration of the call, the arrow indicates incoming ← or outgoing → call. Below that is the date and time the call took place, the line number and the current playback position.

During playback the recorder keys have the usual playback functions. The  and  keys are used to move the playback position a few seconds backward or forward. Keep them pressed to rewind or forward faster. The  key is used to stop playback.

For playback of older stored recordings it is required to select the recording first. Read on for an explanation how to search for the desired recording.

5.2 Search stored recordings

The Call Recorder has a search function to find stored recordings. The search function starts with prompting for the date. The search can be further refined by a search according to remote number and line number. The entered search string for the date will always be preceded by the remote number, which in turn precedes the line number. Wildcards can be used to search for remote number or line number only.

- Press the  key to open the menu.

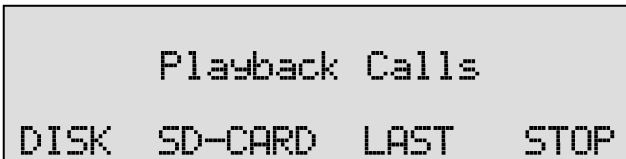

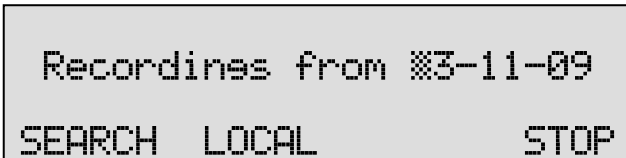

```
Playback Calls
DISK  SD-CARD  LAST  STOP
```

- Select **DISK** or **SD-CARD** to open the search menu.



```
Recordings from 03-11-09
SEARCH  LOCAL          STOP
```

- Use the numerical keys to enter a date.

Entering the date or code to search for you can use the * key as wildcard. For example enter ******:05:09 to search for all recordings from May 2009. The  and  keys can be used to move the cursor left or right.

- Press **SEARCH** to search for recordings by the entered date:

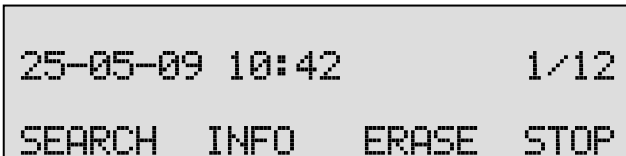

```
25-05-09 10:42          1/12
SEARCH  INFO  ERASE  STOP
```

For the entered date there were 12 recordings found. The first of the 12 recordings is selected for playback, the date and time of the call are

displayed to the left. Use the ◀◀ and ▶▶ keys to step through the recordings.

- Press the ⏮ key to start playback of the selected recording:

```
793471000      ◀  01:25:48
25-05-09 10:42 L1 00:09:42
```

The display shows the remote number, if available. Next to that is the duration of the call, the arrow indicates incoming ◀ or outgoing ▶ call. Below that is the date and time the call took place, the line number and the current playback position.

During playback the recorder keys have the usual playback functions. The ◀◀ and ▶▶ keys are used to move the playback position a few seconds backward or forward. Keep them pressed to rewind or forward faster. The ⏹ key is used to stop playback.

The next section describes how to refine your search to look for a specific number.

5.2.1 Search according to Local number

Open the search menu as described in § 5.2. Remember that the entered date will always be incorporated in the search.

```
Recordings from 08-06-09
SEARCH LOCAL          STOP
```

- Press **LOCAL** to enter a local number to search for.

```
Local: 0_____
SEARCH REMOTE LAST STOP
```

- Use the numerical keys to enter a local number.



Entering the local number to search for you can use the * key as wildcard. For example enter 3520* to search for all recordings which

start with the number 3520. The  and  keys are used to move the blinking character left or right.

- Press **SEARCH** to search for recordings with the entered number:



08-06-09 15:09 1/7
SEARCH INFO ERASE STOP

For the entered number there were 7 recordings found. The first of the recordings is selected for playback, the date and time of the call are displayed to the left. Use the  and  keys to move the selected recording one up or down.

- Press the  key to start playback of the selected recording.

5.2.2 Search according to Remote number

Open the search menu as described in § 5.2.1.



Local: ☒ _____
SEARCH REMOTE LAST STOP

- Press **REMOTE** to enter a remote number to search for:



Remote: ☒ _____
SEARCH CONNECT STOP

- Use the numerical keys to enter a remote number.
- Press **SEARCH** to search for recordings with the entered number.

5.2.3 Search according to Connected number

Open the search menu as described in § 5.2.2.

```
Remote: ☒_____
SEARCH CONNECT STOP
```

- Press **CONNECT** to enter a connected number to search for.

```
Connect: ☒_____
SEARCH DATE STOP
```

The connected number is the actual number the caller is connected to. For an incoming call the connected number will be a local connected number, an outgoing call will display a remote connected number. Note that this often is not the number that is dialed. The connected number often is the number of the extension that answers the call. For various reasons the connected number may not be available. A possible reason is that the number is suppressed by the PBX.

- Use the numerical keys to enter a connected number.
- Press **SEARCH** to search for recordings with the entered number.

5.3 Recording information

Once a recording has been selected from the result of a search as described in §5 above:

```
08-06-09 12:11 1/2
SEARCH INFO ERASE STOP
```

- Press **INFO** to open the info screen of the selected recording:

```
3471005 <- 342475893
BACK
```

Both the local and remote numbers of the call will be displayed together with the arrow indicating an incoming or outgoing call.

- Press **BACK** to return to the search results.

5.4 Erase a recording from the drive

Once a recording has been selected from the result of a search as described in §5 above:

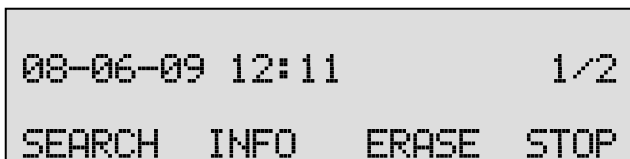

08-06-09 12:11 1/2
SEARCH INFO ERASE STOP

- Press **ERASE** to start the erase operation. A confirmation is asked first:

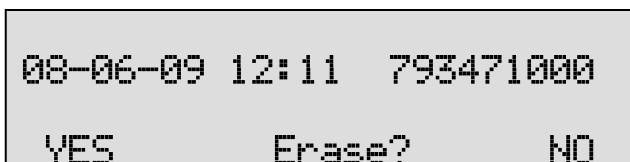

08-06-09 12:11 793471000
YES Erase? NO

- Press **YES** to erase the call.
- Press **NO** to cancel the erase operation.

NOTE: Erasing a recording from the internal drive will overwrite all recorded data with zero bytes. Also the file name with all its information in it is renamed to a not recognizable name.

6 Copy recordings to SD card

It is possible to copy recordings from the internal disk to SD card. There are more ways to copy recordings to SD card. For all ways the Copy function key has to be pressed to initiate the copy.

6.1 Copy the last recording to SD card

- Press the  function key:

```
Recordines from 03-11-09
COPY                LAST  STOP
```

- Press **LAST** to start the copy:

```
Copy Recordine to SD-Card
YES          Start?    NO
```



- Press **YES** to start copying the last recording.
- Press **NO** to cancel the copy.

6.2 Copy a selection of recordings

- Press the  function key:

```
Recordines from 03-11-09
COPY                LAST  STOP
```

- Use the numerical keys to enter a date.

Entering the date or code to search for you can use the * key as wildcard. For example enter **:11:09 to search for all recordings from November 2009. The  and  keys can be used to move the cursor left or right.

- Press **COPY** to start to search:

```

Recordings found: 17
Copy to SD-Card

YES          Start?          NO
  
```

- Press **YES** to start copying the recordings.
- Press **NO** to cancel the copy.

6.3 Copy an individual recording during playback

First select the recording you want to copy as described in chapter §5.2.

```

13-11-09 12:11          1/2
SEARCH  INFO          STOP
  
```

- Press the  **Copy** function key. This is also possible while playback is in progress.

```

Copy Recordings to SD-card

YES          Start?          NO
  
```

- Press **YES** to start copying the recording.

When the recording has been copied:

```

13-11-09 12:11          1/2
SEARCH  INFO  ERASE  STOP
  
```

- Press **STOP** to finish and return to idle mode.

6.4 Copy a selection of recordings (alternative)

First define the search to locate the recordings you want to copy as described in chapter §5.

```
Recordines from 03-11-09
SEARCH LOCAL STOP
```

- Press the  Copy function key in stead of **SEARCH**.

```
Recordines found: 17
Copy to SD-Card
YES Start? NO
```

- Press **YES** to start copying the recordings.
- Press **NO** to cancel the copy.

7 Numberlist

The Call Recorder Single Digital can be configured for the use of a blacklist, a whitelist or no numberlist at all. A blacklist excludes the numbers on it from recording. All other numbers are recorded then. A whitelist includes the numbers on it for recording. All other numbers are not recorded. See chapter 4.10 for the configuration of the numberlist.



7.1 View the Blacklist or Whitelist

Depending on the settings you made in the configuration, you will see a blacklist or whitelist:

- Press the  function key to view the numberlist.



The number "347100" is the first of 70 numbers in the list.

- Press **NEXT** to view the next number in the list
- or use the  and  keys to scroll through the list.

7.2 Add a number to the list

To add a number to the numberlist you need to view the list first as described above.

- Press **NEW** to add a number to the list.



Enter a numeric number. The display will look like this:

```
Number: 3471001*
STORE  <<  CLEAR  CANCEL
```

Enter the number that needs to be added to the list. Wildcards are allowed to enter a range of numbers, e.g. 3471* will block or include all the numbers that start with 3471.

- Press **STORE** to add the number to the list.
- Press **STOP** to leave the numberlist menu

```
Save Changes?
YES      NO      CANCEL
```

- Press **YES** to save the changes.

7.3 Remove a number from the list

To remove a number from the numberlist you need to view the list first as described above. Select the number you want to remove from the list.

```
Blacklist - 2/71
3471001
NEXT  NEW  DELETE  STOP
```

- Press **DELETE** to remove the number from the list.

```
Blacklist - 2/71
3471001
YES      Delete?      NO
```

- Press **YES** to remove the number from the list.

8 Notification message

In this Chapter the recording of the notification message is described. The notification message is used to announce to the remote party that the call is being recorded. The setting of the notification message is described in § 4.9.



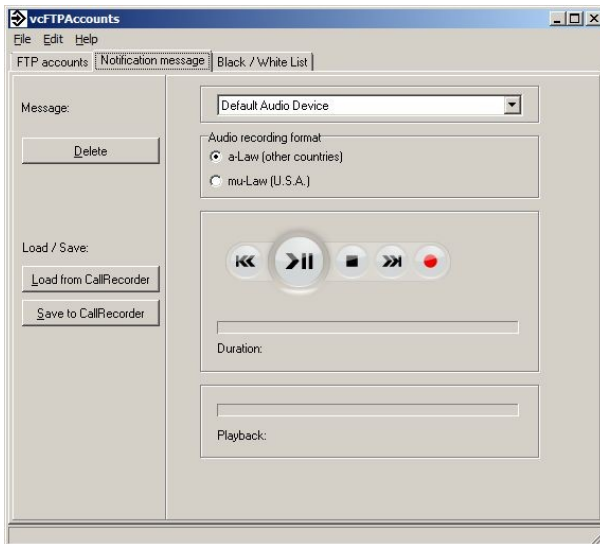

8.1 Record notification message

To record the notification message do the following:

- Insert the Product CD you received with the Call Recorder Single Digital into your PC.
- On it locate the folder 'Utils' and open it.
- In this folder locate 'vcFTPAccounts.exe'
- Install this application and open it.
- Select the tab 'Notification message'



Connect a headset with microphone or microphone to your PC, or use the built in microphone on your PC.

- Press the  key to start recording the message.
- Speak the message into the microphone.
- Press the  key when you are finished.
- Press the  key to listen to the recorded message.
- Press  to save the message to the Call Recorder, the below shown dialogue box will open

or

- Press . If you want to try again.
- Fill in the required IP address and FTP username and password, then click 'OK'

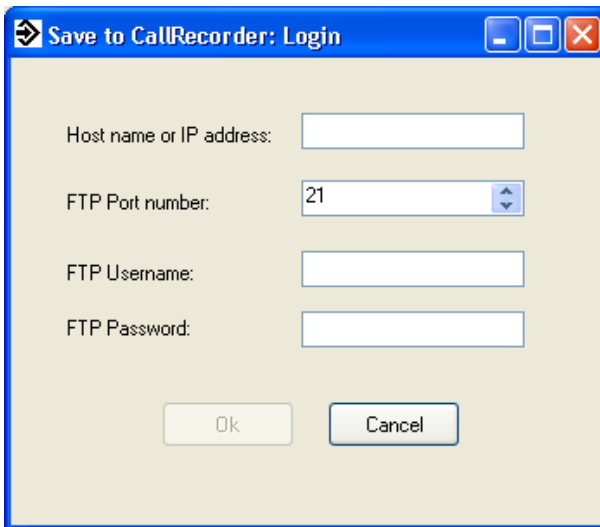

Save to CallRecorder: Login

Host name or IP address:

FTP Port number:

FTP Username:

FTP Password:

Ok Cancel

The Notification message is now transferred to the Call Recorder.

9 Monitoring

Monitoring of the telephone lines is a feature of the Call Recorder that allows the user to listen in on the recording of the telephone conversations.

9.1 Monitoring on the desktop model

- Press the  function key to open the monitor function.

```
Line/Channel Monitor
(Press 1 or 2)

STOP
```

- Press the line/channel number to monitor.

```
Friday 10-07-2009 12:39

Monitor on line 1
```

When line 1 has a call it will be audible through the speaker after pressing the speaker key. Use the volume keys to control the loudspeaker volume.

Stop the monitor by pressing soft-key **STOP** or by pressing the  key.

- Pressing numbers **1** or **2** will change the monitor to the other line/channel, the display will show the line status.

```
Line 2 – (no number)

Free.
```

10 The Information menu

The Call Recorder Single Digital has an information menu with some statistical information.

- Press the  function key to open the information menu.

```
Free on SD: 119 Mb
NEXT                               STOP
```

- Press **NEXT** to continue the Information menu.

```
Free on disk: 3645 Hours
NEXT                               STOP
```

In this example there is 3645 hours of recording time free on the internal Compact Flash card.

- Press **NEXT** to continue the Information menu.

```
Format SD Card
NEXT   START                               STOP
```

- Press **START** to format the SD card.
- Press **NEXT** to continue with the Information menu.

```
Information
NEXT   INFO                               STOP
```

- Press **INFO** to start the listing of various hardware, software and configuration information.
- Press **NEXT** to continue with the Information menu.



- Press **START** to start a firmware update of the Single Digital.

NOTE 1: To do that you need an SD card with a specific file on it that contains a firmware upgrade for the Single Digital. Upgrades will be made available periodically on our website.

NOTE 2: Do not unplug or otherwise disturb the upgrading process, or the Single Digital may become unoperative. In such cases the recorder must be returned to your dealer for repair.

- Press **STOP** to exit the Information menu.

11 LAN Settings

The Call Recorder Single Digital has an Ethernet port. The network interface supports the following protocols:

- FTP server
- SMTP client for sending email messages to a SMTP server
- Telnet for remote configuration
- NTP for automated adjustments of the system clock
- A propriety protocol for streaming audio for remote monitoring

FTP server is used by the Call Recorder Access System for network access to the database in the recorders and playback and archiving of recordings. It can also be used to give other (custom) applications access to the recordings in the recorder.

SMTP gives the recorder the ability to send emails. This has two functions. The first one is that the recorder can send recordings as an attachment to the user. The second is that the recorder can send status updates about the system health, for example that the telephone line is disconnected or that the system is ok.

Telnet give the possibility to a systems manager to access an internal settings menu from remote.

The NTP (Network Time Protocol) is a great method to synchronise the clock of the recorder with an external one somewhere on the network. RTR monitoring is available for users of this special PC software. It will be described later in this manual.

11.1 Network active

To begin the network configuration on the desktop model press:

- Press the  function key to enter the network settings.

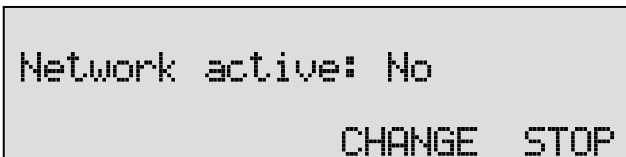

- Press **CHANGE** to enable the network.
- Press **NEXT** to save and move on to the next menu item.

11.2 FTP active

FTP stands for File Transfer Protocol.

```
FTP active:      No
NEXT            CHANGE  STOP
```

- Press **CHANGE** to enable FTP.
- Press **NEXT** to save and move on to the next menu item.

11.3 FTP user

The FTP user is the user name to be used by FTP clients such as the Call Recorder Access software to log on to the recorder.

```
FTP user: 0000
NEXT            CHANGE  STOP
```

- Press **CHANGE** to change the FTP user name.

```
FTP user: vidicode⌘
STORE  <<  CLEAR  CANCEL
```

- Enter the FTP user name

Use the numerical keys to enter the FTP user name. Use  to switch between upper case and lower case characters. The character preceding the cursor will be toggled.

- Press **STORE** to save the FTP user name.
- Press **NEXT** to save and move on to the next menu item.

11.4 FTP password

The FTP password is the password that goes with the FTP user name.

```
FTP Pwd: 0000
NEXT          CHANGE  STOP
```

- Press **CHANGE** to change the FTP password.

```
FTP Pwd: 123❏
STORE  <<  CLEAR  CANCEL
```

Use the numerical keys to enter the FTP password. Use  to switch between upper case and lower case characters. The character preceding the cursor will be toggled.

- Press **STORE** to save the FTP password.
- Press **NEXT** to save and move on to the next menu item.

11.5 FTP server port

FTP server port is the port number through which an FTP client can log on to the recorder. The FTP server port is default set to 21, as is most common. If there is no direct reason to change the FTP server port it is best left unchanged.

```
FTP port:      21
NEXT          CHANGE  STOP
```

- Press **CHANGE** to change the FTP server port number

```
FTP port:      ❏
                                     CANCEL
```

Use the numerical keys to enter the FTP server port number.

- Press **STORE** to save the FTP server port number.
- Press **NEXT** to save and move on to the next menu item.

11.6 DHCP server

In case a DHCP server is used on the network the DHCP server option must be enabled. In case a DHCP server is not used on the network it must be disabled.

```
DHCP server:  No
NEXT          CHANGE  STOP
```

- Press **CHANGE** to enable DHCP server.

```
DHCP server:  Yes
NEXT          CHANGE  STOP
```

- Press **NEXT** to save and move on to the next menu item.

When a DHCP server is used, the IP and Gateway addresses are automatically assigned. Without DHCP server you must manually enter these IP addresses.

11.7 IP address

As part of the network the recorder needs an IP address. In case a DHCP server is used (see previous item) the DHCP server will assign an IP address. In case a DHCP server is not used a static IP address must be assigned to the recorder.

```
IP addr:  0.0.0.0
NEXT          CHANGE  STOP
```

- Press **CHANGE** to enter the IP address

```
IP addr:  000.000.000.000
STORE  <<  >>  CANCEL
```

Use the numerical keys to enter the IP address.

- Press **STORE** to save the IP address.
- Press **NEXT** to save and move on to the next menu item.

11.8 IP subnet mask

The IP subnet mask is used if access from outside the network is required. In this case the Gateway must be entered as well.

```

IP mask:  255.255.255.0
NEXT          CHANGE  STOP
  
```

- Press **CHANGE** to change the IP subnet mask

```

IP mask:  ※55.255.255.000
STORE  <<      >>  CANCEL
  
```

- Enter the IP subnet mask

Use the numerical keys to enter the IP subnet mask.

- Press **STORE** to save the IP subnet mask.
- Press **NEXT** to save and move on to the next menu item.

11.9 Gateway

The Gateway is used if access from outside the network is required. If so the Gateway and the IP subnet mask must be entered.

```

Gateway:  0.0.0.0
NEXT          CHANGE  STOP
  
```

- Press **CHANGE** to enter the Gateway address.

```

Gateway:  ※00.000.000.000
STORE  <<      >>  CANCEL
  
```

Use the numerical keys to enter the Gateway.

- Press **STORE** to save the Gateway.
- Press **NEXT** to save and move on to the next menu item.

11.10 IP name

Aside from the IP address the Call Recorder can also be addressed by an IP name if your DNS server supports this function.

```
IP name: SingleDigital
NEXT          CHANGE  STOP
```

- Press **CHANGE** to enter an IP name.

```
IP name: SingleDigital®
STORE  <<  CLEAR  CANCEL
```

Use the numerical keys to enter an IP name.

- Press **STORE** to save an IP name.
- Press **NEXT** to save and move on to the next menu item.

11.11 E-mail

Status reports and malfunctions can be emailed to this Email address.

```
E-mail: crsd@vidicode.nl
NEXT          CHANGE  STOP
```

- Press **CHANGE** to enter an Email address

```
E-mail: crsd@vidicode.nl®
STORE  <<  CLEAR  CANCEL
```

Use the numerical keys to enter the Email address.

- Press **STORE** to save the Email address.
- Press **NEXT** to move on to the next menu item.

Recording can be emailed according to the extension\email list. For the email list to be operable the main email address has to be a valid email address.

11.12 Reply address

Because the Call Recorder cannot receive Email, the Emails sent require another reply address.

```
Reply: crsd@vidicode.nl
NEXT          CHANGE  STOP
```

- Press **CHANGE** to enter a reply address

```
Reply: crsd@vidicode.nl*
STORE  <<  CLEAR  CANCEL
```

Use the numerical keys to enter the Email reply address.

- Press **STORE** to save the Email reply address.
- Press **NEXT** to move on to the next menu item.

11.13 SMTP server IP address

The recorder requires the IP address of the SMTP server to send Email. In case a local SMTP server is used the IP number can be entered directly. In case of an SMTP server outside the network both the **Gateway** and the **Subnet Mask** need to be set later on.

```
SMTP srv: 0.0.0.0
NEXT          CHANGE  STOP
```

- Press **CHANGE** to enter the IP address of the SMTP server.

```
SMTP srv: 0.0.0.0⌘
STORE  <<  CLEAR  CANCEL
```

Use the numerical keys to enter the IP address of the SMTP server. Either an IP number or IP name are allowed. In case an IP name is used the DNS server needs to be configured.

- Press **STORE** to save the IP address of the SMTP server.
- Press **NEXT** to move on to the next menu item.

11.14 SMTP server port

SMTP-server port is the port number through which the connection is to be made with the SMTP server. The SMTP-server port is default set to 25. Do not change the SMTP port number when this value is not explicitly changed in the SMTP server.

```
SMTP Port:      25
NEXT           CHANGE  STOP
```

- Press **CHANGE** to change the SMTP port number.

```
SMTP Port:      ⌘
                                CANCEL
```

Use the numerical keys to enter the SMTP port number.

- Press **STORE** to save the SMTP port number.
- Press **NEXT** to move on to the next menu item.

11.15 Domain name

The domain name of the SMTP server is also required. In case the SMTP server is on the network the network domain is required. In case the

SMTP server is outside the network the domain name of the SMTP server is required. Contact your provider for more information.

```
Domain: vidicode.nl
NEXT          CHANGE  STOP
```

- Press **CHANGE** to enter the domain of the SMTP server.

```
Domain: vidicode.nl
STORE  <<  CLEAR  CANCEL
```

Use the numerical keys to enter the domain of the SMTP server.

- Press **STORE** to save the domain of the SMTP server.
- Press **NEXT** to move on to the next menu item.

11.16 DNS server

In case an IP name has been configured for your SMTP server you need to configure the IP number of the Domain Name Server.

```
DNS srv: 0.0.0.0
NEXT          CHANGE  STOP
```

- Press **CHANGE** to enter the IP number of the DNS server

```
DNS srv: 000.000.000.000
STORE  <<  >>  CANCEL
```

Use the numerical keys to enter the DNS server.

- Press **STORE** to save the IP number of the DNS server address.
- Press **NEXT** to save and move on to the next menu item.

11.17 NTP server

If it is possible that on your network the Call Recorder has access to an NTP (Network Time Protocol) server, it is recommended that you enable it because it will give the recorder an accurate time reference.

```
NTP srv:  0.0.0.0
NEXT          CHANGE  STOP
```

- Press **CHANGE** to enter the NTP server address.

```
NTP srv:  0.0.0.0⌘
STORE  <<  CLEAR  CANCEL
```

Use the numerical keys to enter the NTP server. Either an IP number or IP name are allowed. In case an IP name is used the DNS server needs to be configured.

- Press **STORE** to save the NTP server address.
- Press **NEXT** to save and move on to the next menu item.

11.18 NTP port

NTP port is the port number through which the recorder as a client can connect to the NTP server. The NTP port is default set to 123. Consult the network manager for the port number.

```
NTP Port:  123
NEXT          CHANGE  STOP
```

- Press **CHANGE** to change the NTP server port number.

```
NTP Port:  ⌘
CANCELED
```

Use the numerical keys to enter the NTP port number.

- Press **STORE** to save the NTP server port number.
- Press **NEXT** to save and move on to the next menu item.

11.19 GMT correction

GMT correction property is used to identify the time zone. NTP server normally issues GMT (also known as UTC). GMT correction can be set in half hours from -15:00 to + 15:00.

```
GMT correction: 00:00
NEXT      - CHANGE +      STOP
```

- Press **CHANGE** to set GMT correction. Keep pressing **CHANGE** to increase the correction. It will start with + 1:00, keep pressing **CHANGE** to increase. After + 15:00 there will appear - 15:00.
- Press **NEXT** to save and move on to the next menu item.

GMT correction refers to winter time. Summertime / Daylight saving time and Wintertime are corrected automatically.

11.20 Telnet

Telnet can be used to log on to the recorder and configure it from your PC remotely. If required contact your supplier for more details.

```
TelNet active: No
NEXT          CHANGE  STOP
```

- Press **CHANGE** to enable TelNet.

```
TelNet active: Yes
NEXT          CHANGE  STOP
```

- Press **NEXT** to save and move on to the next menu item.

11.21 Service timer

The Service timer determines the performance of the network connection. Default the Service timer is set to Automatic. Changing the setting should only be done when advised by a service engineer to solve problems.

```
Service Timer: Auto
NEXT          CHANGE  STOP
```

- Press **CHANGE** to change the Service timer.

The following settings are available: S1-S5, F1-F3 and U1-U3. Where S stands for Slow, F for Fast and U for Ultra fast.

- Press **NEXT** to save and move on to the next menu item.

11.22 Monitor active

The monitor function allows you to listen to the conversations that take place. This requires the RTR Call Monitor software, which connects with the recorder over the network.

```
Monitor active: No
                CHANGE  STOP
```

- Press **CHANGE** to enable the Monitor.
- Press **NEXT** to move on to the Monitor password.

The monitor password is used to log on to the recorder. This password must also be set in the RTR Call Monitor software.

```
Monitor Pwd: 0000
                CHANGE  STOP
```

- Press **CHANGE** to enter a password
- Press **STOP** to exit the network setting menu



Use the numerical keys to enter the Monitor password. Use  to switch between upper case and lower case characters. The character preceding the cursor will be toggled.

- Press **STORE** to save the Monitor password.

12 Encrypted recording

The Call Recorder Single Digital features a system for encrypted recording whereby IC cards called CryptoCards are used as a key. Encrypted recordings are made to prevent unauthorized playback of and listening to recordings. The system is very safe and recommended when some sort of security breach is possible. Examples of such a situation are:

- The recorder is connected to a network or even internet and there are reasons to think that password security is not enough.
- The recorder can be accessed and operated by persons who are not allowed to listen to all recordings and there are reasons to think that password security is not enough.
- Privacy is considered to be an issue and therefore strict procedures must be maintained around listening to the recordings.

The CryptoCard is a chip card that holds the key to the encryption and decryption. Encrypted recordings can only be played back together with the original or a matching CryptoCard and its password.

The recorder is equipped with an external card reader specifically for this purpose; it is located on the left front side of the device.

CryptoCards can be obtained from your Vidicode products supplier. The use of the CryptoCard encryption function is enabled in the Settings menu. See § 4.14 to enable the use of a CryptoCard.

12.1 Several types of CryptoCard

As mentioned there are cards that can be used for recording and for playback and there are cards that can be used for recording only, the so called "Privacy Cards". It is important to understand the difference.

- When it is important to be able to listen to recordings on the recorder, use the standard CryptoCard.
- When you prefer that it is not possible to listen to recordings on the recorder, use the CryptoCard Privacy card.

It is also possible to supply sets of individual cards with a "Master Card" that can be used to decode all the individual cards. The application is when employees are only allowed to listen to their own recordings while, when needed, the management must have the ability to listen to all recordings.

12.2 Insert a CryptoCard into the recorder

Insert the CryptoCard into the Call Recorder Single Digital as shown in the figure below.

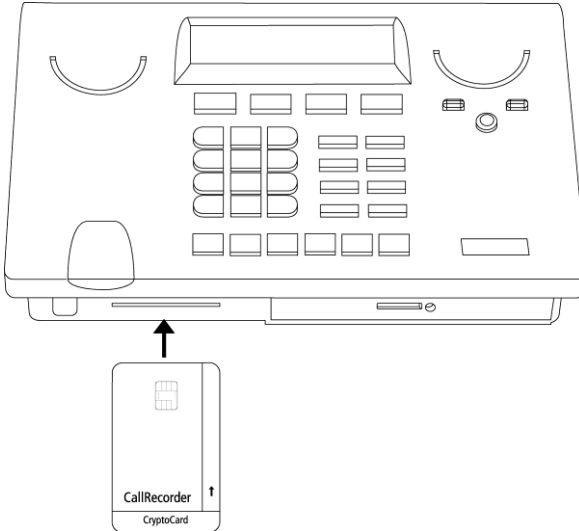

12.3 The CryptoCard and its PIN and PUC code

The CryptoCard is supplied with a PUC code and a PIN code. The PIN code is a four-digit code and is requested to enable playback of recordings. The PUC code is a twelve-digit code and is used only when the card has been disabled. The PIN code can be changed with the recorder. This can be done only when the Use CryptoCard function has been enabled..

- Press the  Recorder function key.
- Press **NEXT** several times.



- Press **CHANGE** to change the card code.

First enter the original card code.

- Press CONTINUE.

Enter the new card code.

- Press CONTINUE.

Repeat the new card code for confirmation.

- Press CONTINUE.

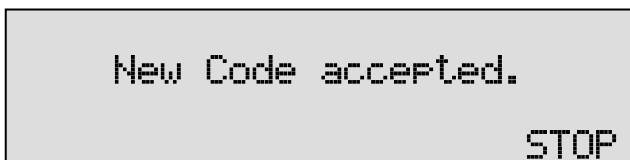

The new card code is accepted.

- Press **STOP** to exit the Change Card Code menu

A CryptoCard allows for two invalid PIN code entries. After the third invalid Pin code entry the CryptoCard is disabled. The next time the recorder will ask for the PUC code to enable the card again. The CryptoCard allows for four invalid PUC code entries. After the fifth invalid PUC code entry the recorder will disable the card definitively. It is advised to keep the PUC code in a safe place.

12.4 Making an encrypted recording

To make an encrypted recording it is essential that the Use CryptoCard function is enabled in the Recorder settings menu. Enable the Use CryptoCard function as described in § 4.14. With Use CryptoCard enabled it is no longer possible to make normal, unencrypted recordings without disabling the Use CryptoCard function again.

Insert the CryptoCard in the card reader of the recorder:

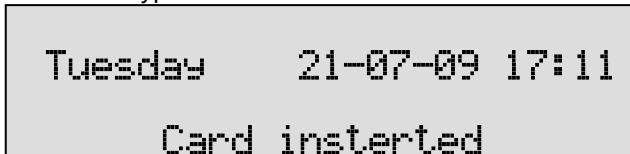

When a valid CryptoCard has been inserted all recordings made thereafter will be encrypted as long as the card remains inserted.

Removing the card disables recording automatically.

Encrypted recordings are stored as such and can be played only with a matching CryptoCard inserted. Encrypted recordings can also be

downloaded to a PC with the Call Recorder Access System software, however, they cannot be played on the PC without a CryptoCard matching the card used when the recording was made. See the following section for a detailed explanation.

12.5 Playing an encrypted recording

Encrypted recordings can only be played back with the original or a matching CryptoCard. For playback of an encrypted recording on the recorder this works quite simply. Search and select the desired recording as described in Chapter 5.

If playback of the encrypted recording is started the recorder will automatically ask for the Card code.:



- Enter your card code.

After entering your PIN code the soft-key function CONTINUE is added in the display.

- Press **CONTINUE** to start playback of the selected recording.

It is not necessary to enter your card code every time.

12.6 Using CryptoCards on a PC

Recordings can be played on a PC with the Call Recorder Access System application on it and with the original or matching CryptoCard. Encrypted recordings cannot be played on the PC without the original or a matching CryptoCard. Your supplier of the recorder can supply you with a Card reader for your PC together with the necessary drivers. The Call Recorder Access System application will show whether recordings are encrypted in the "Use of CryptoCard" column. When an encrypted recording is played the Call Recorder Access System application will prompt you for the insertion of a matching card and the belonging code. After that the recording will play. The Call Recorder Access System has the ability to remove the encryption. Encrypted recordings can be exchanged with other PC's just as any other recording.

13 Acknowledgements

13.1 Privacy

When recording telephone conversations the Privacy of your conversation partner must be considered.

In some countries there is an obligation to notify your conversation partner of the recording. Check your national legal obligations on this and other issues concerning the use of the recorder.

In the United States, the Federal government requires that only one person involved in a conversation must know the call is being recorded. However, each state has its own legislation. The vast majority of states have laws complying with the Federal "one party" requirement. A few states, such as Florida and others, do require both parties to be aware the call is being recorded.

The Single Digital can comply both with the one party or two party requirements. One party simply means the person with the recorder knows the call is being recorded. Compliance is made with two party requirements by sounding a notification tone during the call.

13.2 Guarantee

Your Call Recorder Single Digital has a 12-month factory guarantee. The guarantee is effective for normal use only. We would like to emphasize that the guarantee is not valid under exceptional environmental conditions, such as extreme temperatures or humidity levels, nor in the unlikely event of a lightning strike. The guarantee is not valid if the machine has not been handled properly, for example when it has been dropped, or bumped into. In order to qualify for guarantee, you should contact your supplier, and show the receipt. If your supplier cannot help you, you should contact the manufacturer. The manufacturer reserves the right to determine the final date of the guarantee period on the basis of the date of production. Costs of transport to and from the supplier or the manufacturer are for the buyer's account. Guarantee is for parts only and does not cover any costs resulting from the breakdown of the recorder.

The Call Recorder Single Digital has various extra features that have not been described in this manual. Additional information about this is given in a technical information bulletin. Subjects discussed in this technical documentation are further configuration options, remote configuring, and how to update the firmware in the recorder. The further configuration options concern all aspects of operation. In our

experience most people are interested in configurations related to user's access.

13.3 Liability

Correct functioning of the Call Recorder Single Digital cannot be guaranteed under all conditions and thus we do not accept any liability for loss of information or other damages due to the use of the recorder. Vidicode assumes no liability regarding incorrect notification of call recording.

Vidicode is not a source of official interpretation of laws of any country or state and shall not be construed as a source for making decisions.

14 Index

A

| | |
|--------------------------|----|
| Acknowledgements | 66 |
| Alfa-numerical functions | 6 |

C

| | |
|----------------------|--------|
| Care and Maintenance | 7 |
| Clock | 31 |
| Connect | |
| power supply | 17 |
| telephone lines | 18 |
| Copy a selection | 41 |
| Copy recordings | 39 |
| CryptoCard | 29, 63 |

D

| | |
|-------------|----|
| DHCP server | 52 |
| Domain name | 56 |

E

| | |
|---------------------|--------|
| E-mail address | |
| Fax Server | 54, 55 |
| Encrypted recording | 62 |
| Ethernet interface | 14, 49 |

F

| | |
|---------------|----|
| FTP | 50 |
| password | 50 |
| user name | 50 |
| Function keys | 20 |
| Function-keys | 5 |

G

| | |
|-----------|----|
| G.723 | 14 |
| Gateway | 53 |
| Guarantee | 66 |

H

| | |
|----------------|----|
| Hard disk menu | 47 |
|----------------|----|

I

| | |
|--------------|----|
| Index | 68 |
| Introduction | 13 |
| IP address | 52 |
| IP name | 54 |

L

| | |
|----------------|----|
| Language | 32 |
| Last recording | 33 |
| Liability | 67 |

M

| | |
|---------------------|----|
| Menu keys | 20 |
| Menu-key indicators | 21 |

N

| | |
|---------------|------------|
| Network | |
| FTP | 50 |
| gateway | 53 |
| IP address | 52 |
| Monitor | 60 |
| Service timer | 60 |
| subnet mask | 53 |
| Notification | 25, 27, 44 |
| record | 44 |
| Numberlist | 28 |
| add number | 42 |
| blacklist | 28 |
| remove number | 43 |
| view | 42 |
| whitelist | 28 |

P

| | |
|---------------------|----|
| Password protection | 30 |
|---------------------|----|

| | | | |
|-----------------------|--------|--------------------|--------|
| remove | 31 | Signaal-instelling | 24 |
| Playback | 33 | SMTP server | 55 |
| Power supply | 17 | SMTP-server port | 56 |
| R | | Stored recordings | 34 |
| Recorder settings | 22 | Subnet mask | 53 |
| Recording information | 37 | T | |
| Reply address | 55 | TelNet | 59 |
| S | | U | |
| Search | | User interface | 20 |
| Connected number | 36 | W | |
| Local number | 35 | Wildcard | 34, 39 |
| recordings | 34 | | |
| Remote number | 36 | | |
| Server port | 51, 58 | | |
| Service timer | 60 | | |