

Call Recorder Pico Manual

V2.5
VC2000



vidicode

Vidicode

Blauw-roodlaan 140
2718 SK Zoetermeer
The Netherlands

Phone

+31(0)79 3471000

Fax

+31(0)79 3618092

Sales

+31(0)79 3471010

Support

+31(0)79 3471005

Email

info@vidicode.com

Internet



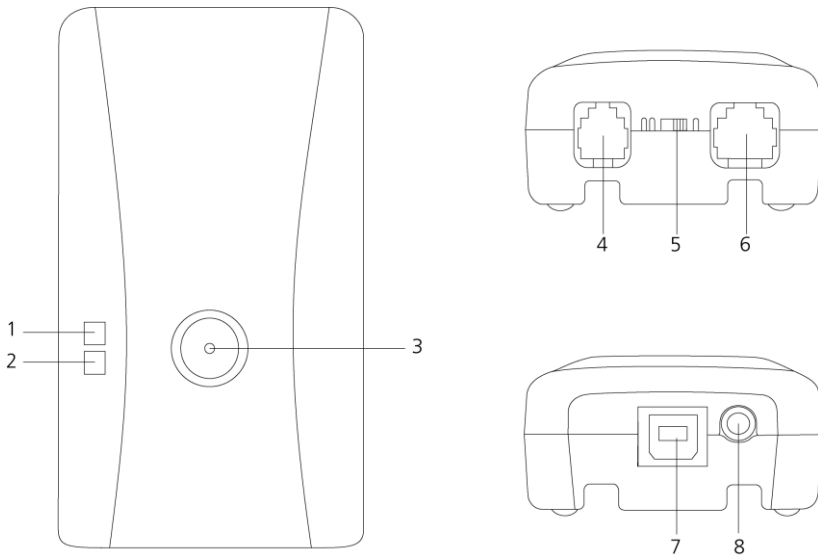

www.vidicode.com



1. Green LED *
2. Red LED **
3. Record button
4. Handset out / Line out
5. I II Switch
6. Handset in / Line in
7. USB
8. Speaker / microphone ***

- *) The green LED indicates that the software on the computer has detected the Pico and its driver is running.
- **) The red LED indicates a recording is being made.
- ***) Connect a microphone to record a conversation in the room, or connect speakers to play back a previously made recording.

Care and Maintenance

	<p>Keep the Call Recorder Pico dry. If it gets wet, wipe it dry immediately with a soft, clean cloth. Liquids might contain minerals that corrode the electronic circuits.</p>
	<p>Use and store the Call Recorder Pico only in temperature conditions between 0 and 40 degrees Celsius. Temperature extremes can shorten the life of electronic devices and distort or melt plastic parts.</p>
	<p>Keep the Call Recorder Pico away from excessive dust and dirt.</p>
	<p>Do not use aggressive chemicals, cleaning solvents or strong detergents to clean the Call Recorder Pico.</p>

Contents

1	Introduction	7
2	Getting started.....	8
2.1	Hardware installation.....	8
2.2	Notification.....	8
2.3	Connecting the Call Recorder Pico.....	8
2.3.1	Record from telephone line.....	9
2.3.2	Record from handset	9
2.3.3	Record from microphone	10
2.4	Connect the Pico to the PC.....	11
2.4.1	Connecting the first Call Recorder Pico.....	11
2.5	Software installation	11
2.5.1	Software configuration	12
2.5.2	Connecting more Call Recorders Pico	14
3	Options	15
3.1	Language	15
3.2	Device settings.....	15
3.2.1	Basic	15
3.2.2	Start / Stop	17
3.2.3	Volume.....	18
3.2.4	Extra.....	20
3.3	Setup.....	21
3.3.1	Playback.....	21
3.3.2	Recording.....	21
3.3.3	Notification message	23
3.3.4	Screen.....	26

3.3.5	License.....	27
3.3.6	Data storage.....	28
3.3.7	Start / Exit.....	29
3.3.8	Security	31
3.3.9	Display	31
4	Playback and recording.....	33
4.1	Normal playback	33
4.2	Playback in a call	33
4.2.1	Playback and recording control display.....	34
4.2.2	Hotkeys.....	35
4.2.3	Using the Pico device as speaker output.....	35
4.3	Automatic recording.....	35
4.4	Manual recording	35
4.4.1	Adding notes to a recording	35
5	Layout of the software	37
5.1	Main Menu	37
5.1.1	File.....	37
5.1.2	View	38
5.1.3	List.....	39
5.1.4	The Recycle Bin.....	40
5.1.5	Action.....	41
5.2	List, Search and Audio buttons.....	45
5.2.1	The List button	45
5.2.2	The Search button.....	45
5.2.3	The Audio button.....	46
6	Problem solving	48
6.1	Restoring your soundcard	48

6.2	Software does not detect the Pico hardware	48
6.3	Kaspersky blocks access to the audio device	50
6.4	Windows does not detect the Pico hardware	50
6.5	Problems setting the Start/Stop level	51
6.6	Problems setting the Stop time	51
6.7	Problem with playback volume slider	51
6.8	Problems with distorted audio	52
6.9	Problems with high Start level	52
6.10	Problems with automatic start / stop	52
6.11	Problems with PC start up after connecting Pico	55
6.12	Detection of Telephone Numbers	55
7	Software Update Online	57
8	Acknowledgements	58
8.1	Privacy	58
8.2	Liability	58
	Appendix A – Automation interface	59

1 Introduction

The Call Recorder Pico is a system to record and archive telephone calls on a PC. It consists of a PC application and one or more Call Recorders connecting the telephones to your PC. Depending on the number of USB ports and the capabilities of the PC, it is possible to record from up to any number of Call Recorders simultaneously (4 Call Recorders per 1Ghz).

Every gigabyte of free disk space allows you to record up to 180 hours of conversation on your hard disk.

The Call Recorder Pico can record from analogue and corded digital telephones, and from a microphone.

Recordings are stored in a comprehensive archive. The archive is displayed on your computer screen as a list of recordings. In the list the recording properties like date and time of the recording are stored with the actual recording and can be viewed in the archive. Queries can be made to get a clear picture of the amount of recordings or to find a specific recording quickly.

NOTE The Pico stores all recordings on your PC. For it to make a recording it is necessary that the PC is on and the software is running.

Call Centre use

This call recorder can be used in small businesses where one telephone line is connected to one call recorder, but it is also possible to connect a Pico to every line in a Call centre.

For the use of Pico's in a Call centre an API can be installed through which the Pico and the Call Centre's software can work together.

Read Appendix A to find out more about this API.

2 Getting started

The Call recorder Pico is set up in a sequence of steps. The following paragraphs will describe the steps involved. They are:

- Connecting the Pico to the telephone
- Connecting the Pico to the PC
- Software installation
- Set up of the software

2.1 Hardware installation

Depending on the kind of telephone you want to record from, the Pico is connected to the telephone line or the telephone handset. You will find instructions for recording from an analogue telephone line or recording from the handset of a digital telephone. The Call Recorder Pico works best with a properly installed sound card or sound device in your PC. However, the Pico can also be connected to external speakers. The signal on the speakers is a mono signal.

Important note: The hardware installation of a Pico will make this device the preferred sound device of your computer because it is the last device added. If you have a soundcard in your system and you use it for other applications it is advised to restore the original sound device as preferred device again. See [Restoring your soundcard](#) for details.

2.2 Notification

When recording a conversation with the Pico it is possible to notify your conversation partner of the recording through a regularly returning beep or through a spoken message. See § Setup3.3.3 about recording and play back of the notification message.

2.3 Connecting the Call Recorder Pico

Determine the kind of telephone you want to connect the Pico to. This will either be a normal (analogue) or digital (e.g. Key System, PBX, ISDN) device. If you have an analogue telephone, use the "Record from telephone line" method. If you have digital telephone, use the "Record from handset" method.

2.3.1 Record from telephone line

Record from telephone line can only be used if you have an analogue telephone. When "record from telephone line" is used the Pico can detect "on/off hook" straight from the telephone line.

The switch between the telephone sockets **must** be in position I.

If you have a cordless analogue telephone set, connect the Pico to the base unit.

If you have ADSL, connect the Pico between the ADSL modem and the telephone. See the diagram below.

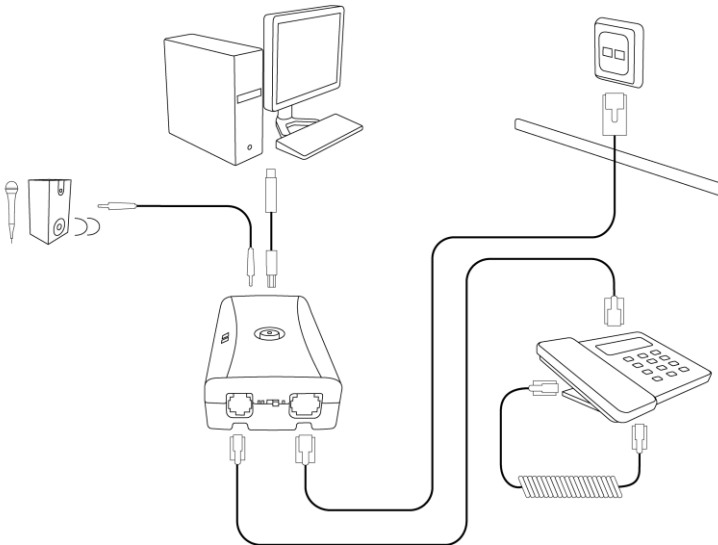

Record from telephone line

2.3.2 Record from handset

When "record from handset" is used the Pico needs to detect "on/off hook" by "listening" to the handset. The handset **must** be corded. The switch between the telephone sockets should be in position I.

Depending on the wiring of your handset you may need to put it in position II if position I interferes with the normal working order of your telephone or the recordings are of poor quality. See also Problems with distorted audio § 6.8. See the connection diagram below.

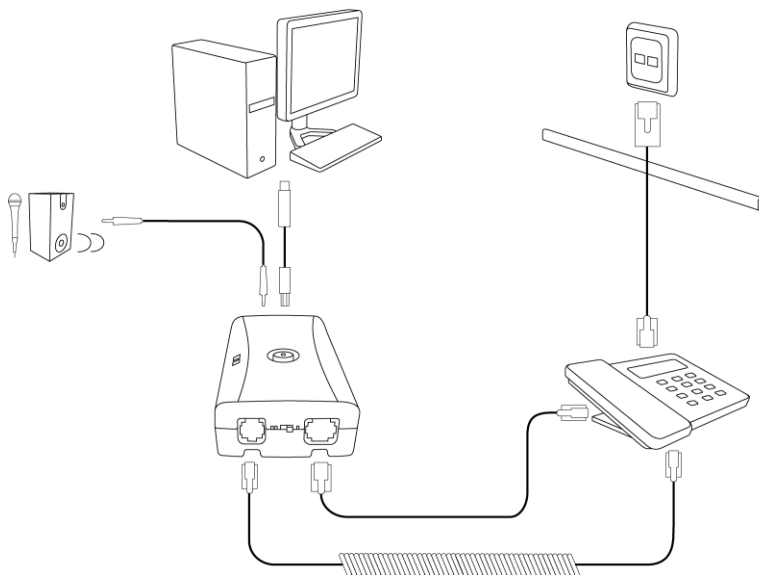

Record from handset

2.3.3 Record from microphone

A third possibility is connecting the Pico to a microphone. Conversations in a conference room or office could be recorded with the Pico connected like this.

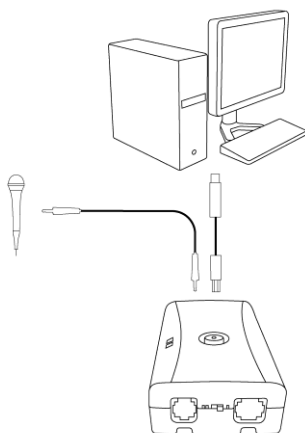

After connecting the Pico to the telephone line or microphone, it can be connected to the PC.

2.4 Connect the Pico to the PC

Once the Pico is connected to the telephone it can be connected to the computer using the USB cable.

2.4.1 Connecting the first Call Recorder Pico

The Pico can be connected to any free USB port or to a USB hub. If connected to a hub, this hub should have an external power supply. For Windows XP, Vista, 7, 8 and 10, the Pico will show up in the device list after a couple of seconds.

Warning: Installing the Pico will make it the preferred sound device of your computer. If you have a soundcard in your system and you use it for other applications it is advised to restore your original sound device as preferred device. To restore your original sound device (your soundcard) as preferred, please follow these instructions:

- Click "Start" and select the Control Panel.
- Select "Multimedia" or "Sound and Multimedia"
- Select the Audio tab-page.
- Now select your preferred device for playback.

2.5 Software installation

Download the Call Recorder Pico software from <https://www.vidicode.com/service-and-support/software/>
The file is called 'CRPicoInstall.exe'.

You can also use the installer from the CD-ROM, if you received one. Place the CD-ROM in your computer and the software installation starts automatically. If the installation is not started automatically, locate the file 'CRPicoInstaller.exe' on the CD.

Start the installer by double-clicking. Follow the instructions on the screen.

- Select your preferred language for the installation.
- You are prompted to accept the software license agreement.
- Now enter the user details and the installation key provided with your product

Setup - Call Recorder Pico

User Information
Please enter your information.

User Name:

Organization:

Installation key:

< Back Next > Cancel

Only then you can proceed with the next steps of the installation:
You will be asked:

- to confirm the location on your hard drive where the software will be installed
- specify a location for the data files
- whether you want a desktop icon for the application

When the installation is finished you will be asked to register your Pico on line.

When the software starts for the first time you will be prompted to check for online updates. Please execute this check to get the latest version. Then close the software and start the software again.

2.5.1 Software configuration

When you start the software for the first time, with the new Pico connected, the **Device list** will open.

Make the connection and recording settings there. See Device settings §3.2.

Windows 10 introduced new “Microphone privacy settings”, which can be found in the Settings app of Windows. In this screen, it is needed that

“Allow apps to access your microphone” is enabled, to allow CR Pico to record audio. See the picture below.

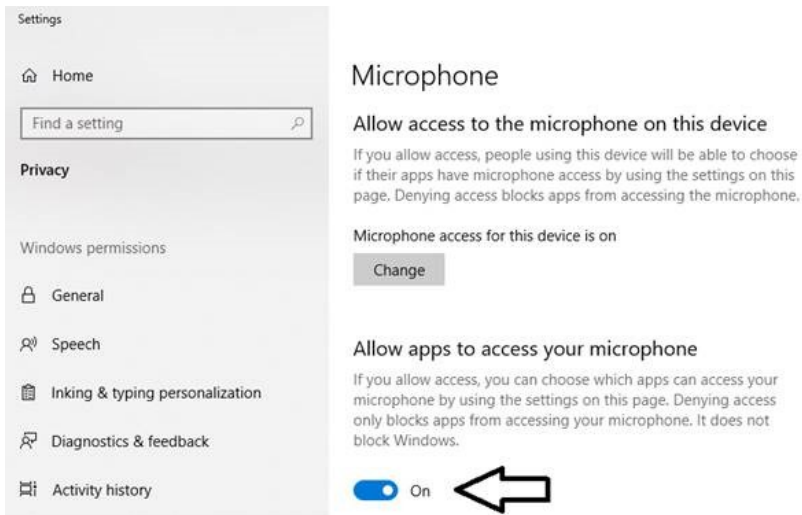

In some cases the CR Pico Line device is not available. To correct this, set it as default recording device. See the picture below.

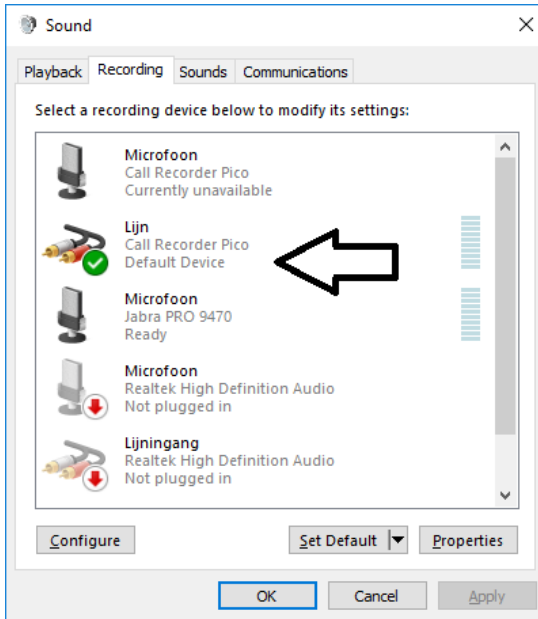

2.5.2 Connecting more Call Recorders Pico

Once the first Pico has been connected, recognised by the PC and it shows up in your device list, the second Pico can be connected. Wait until this device has been recognised and installed before connecting consecutive devices. If you connect a number of Pico's, make sure to give them a 'device name' , to make identification easier.

3 Options

3.1 Language

The Pico software is translated into a number of languages. It is possible to change the display language at any time. Go to Language of the **Options** menu. Select your preferred language and click.

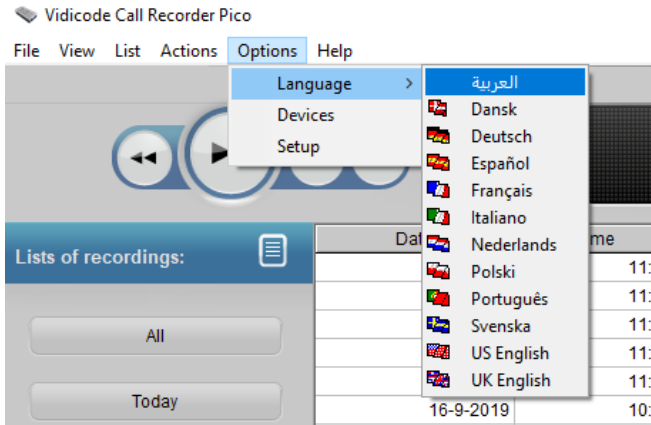

3.2 Device settings

Following the description in the previous paragraph, start the software and open from the **Options** menu the **Devices** screen.

To the left you will see a list in a drop box of the available audio devices. All connected Pico's should show up in the list.

Make the device settings for all Call Recorders separately.

Select one of the audio devices, and then change its settings.

Icon

By default, the Serial number is used as the device name. An enabled Pico shows up as a button in the List tab.

3.2.1 Basic

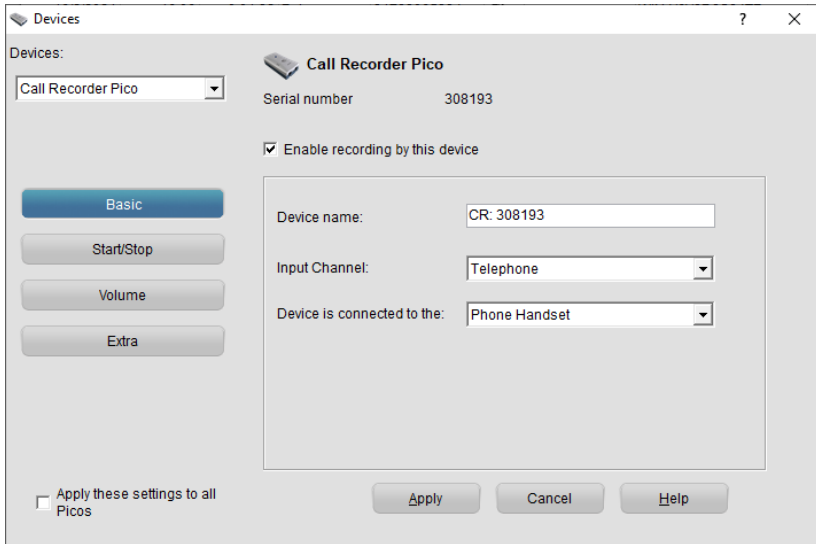

Device name

Each Pico is identified by its serial number. For the individual user it is easier to address a name to the Pico to identify it. The name is referred to as the 'Device name'.

- Enter a name for the device in the 'Device name' field.

Input channel

The Call Recorder Pico can record from a telephone or a microphone. To record from a microphone, connect it to the Pico.

- Select 'microphone' as Input Channel.

It is not possible to record from a telephone and a microphone at the same time.

Device is connected to the:

- Select either the telephone Line or to the telephone Handset according to the way the Pico is connected.

Enable recording by this device

If you want the Pico to record, this checkbox should be checked (it is checked by default). At some point however, it could be necessary to disconnect one or more Pico's. Use this checkbox to disable recording from the device, without having to physically disconnect it.

- Check the "Enable recording by this device" checkbox

Once the device is enabled, other options can be set.

3.2.2 Start / Stop

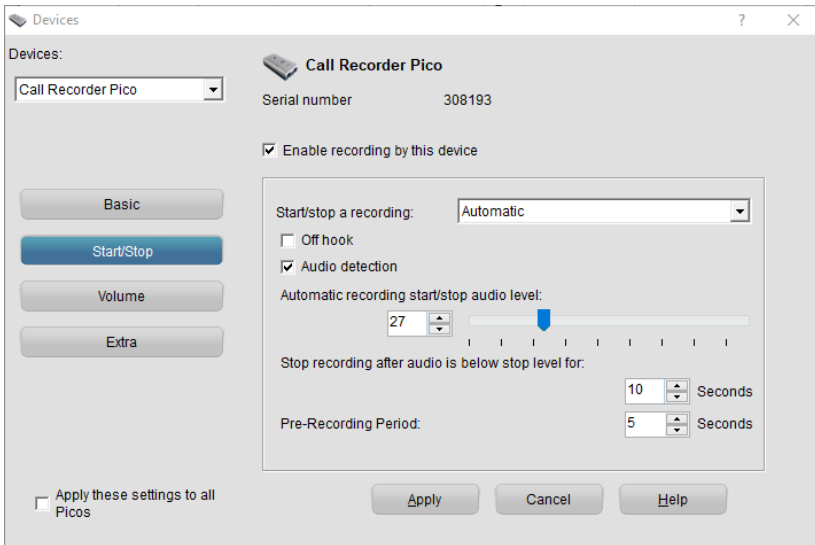

Start / Stop a recording

There are four possibilities:

- 🔊 **Automatic:** The software automatically starts recording when it detects that the telephone is off-hook, based on the audio level and on / off hook signals when available. It is necessary to adjust all settings in this dialogue.
- 🔊 **Semi-automatic:** The software detects when the telephone is off-hook or on-hook, but it does not start a recording automatically. You can choose to start a recording when the telephone is off-hook, by clicking the Record button in the Pico application or press the Record button on the Pico itself. Only adjust the Pre-recording period in this dialogue
- 🔊 **Manual:** You choose to start and stop a recording manually. Recording can be started and stopped from the Audio screen. Recording can also be started from the Active dialog or by using the Record button on the Pico itself. Only adjust the Pre-recording period in this dialogue.
- 🔊 **Automatic (on / off hook only):** The software automatically starts recording when it detects that the telephone is off-hook, based on on-hook signals only, not on audio level. This option is not possible when the Pico is connected to the handset (digital telephone).

About Voice activated recording

Voice activated recording is used when recording from the Handset. This option is used when recording from a digital telephone.

The principle of voice activated recording is quite simple. The Pico software constantly monitors the connected devices for their audio level. When the telephone is not used the audio level is close to zero. When a telephone conversation is started the software will detect an elevated audio level on the Pico. The **Start/Stop level** setting is used to determine the audio level above which recording should be started. The recording will be stopped again when the audio level drops below the Start/Stop level.

However, the recording should not stop instantly. During telephone calls it is possible that the audio level drops below the Start/Stop level for a certain amount of time, for instance when the caller is put on hold or when the caller mutes the phone. Therefore, the recording needs to be stopped only after the audio level has dropped below the Start/Stop level for a certain amount of time. This amount of time is set by the **Stop time**. The settings of the Start/Stop level and the Stop time are crucial to the performance of reliable voice activated recording.

Note Voice activated recording is active simultaneously with the On and Off Hook detection when connected to the telephone line.

Automatic recording start/stop audio level

If the audio level is above the level specified here, a recording will be started.

Stop recording after audio is below stop level for ... seconds

Specify the number of seconds you want the Pico to go on recording after the audio level is below the automatic recording start/stop level.

Pre-recording period

When you manually start a recording it is possible to have the software start the recording a little earlier than you actually press the button by setting the 'Pre recording period' which defines the amount of time.

3.2.3 Volume

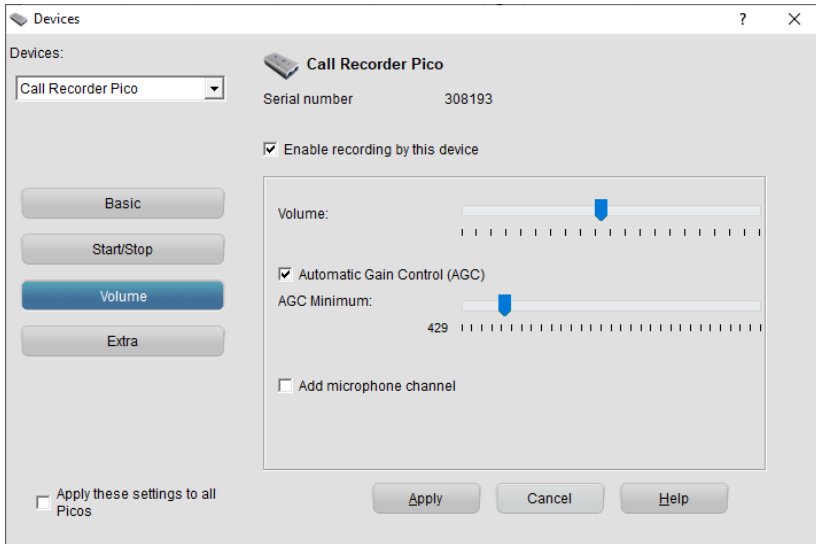

Recording Volume

Here is where you set the recording volume. It is dependent on the make of the telephone whether it should be high or low.

Automatic Gain Control (AGC)

AGC amplifies all audio signals to one specific level.

- Set the minimum level using the second (lower) slider.

The slider sets the Minimum level to boost, i.e. audio (background noise) that stays below this level will remain unaffected (not amplified) by the AGC. Audio that rises above this level will be amplified to the Maximum level.

Try to find a setting where both the local and remote voices are amplified without the background noise being amplified. If during playback the sound seems intermitted or contains gaps the Minimum level is probably set too high. If there is a lot of background noise during playback the Minimum level is probably set too low.

Add microphone channel

By default this option is not enabled. This option is only relevant when the device is connected to the telephone handset. The Pico software, by default, only records the headset speaker channel. Most telephone handset speakers contain both the local and the remote voice signal.

Enable this option to add the local voice signal from the microphone to the recording. Enable this option only when the recording does not contain the local voice or when the audio level is too low.

3.2.4 Extra

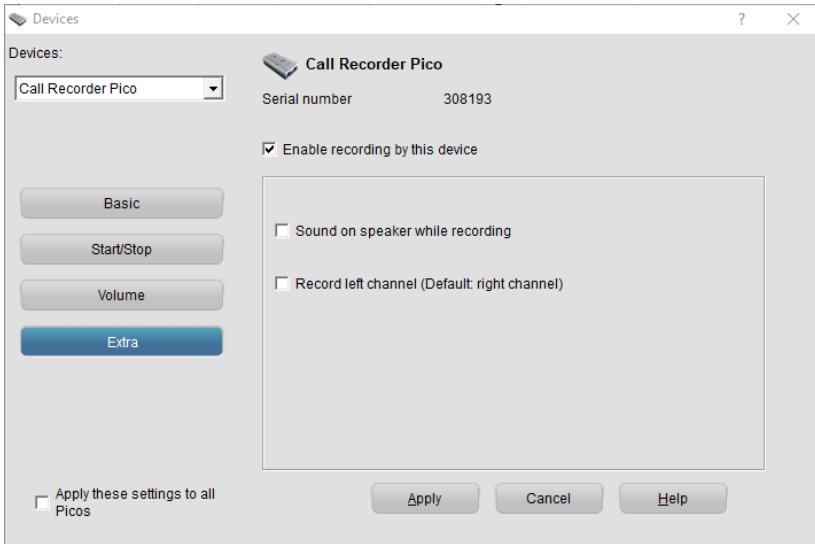

Sound on speaker while recording

This is a Monitoring option.

When this option is enabled, the recorded sound is put on the PC speakers automatically when a recording starts, and is stopped automatically when the recording stops. This option allows for supervisors in an other room to listen in on the conversation that is taking place. As the sound is not real time it is not advised to enable this option when the telephone and the PC are in the same room. This option can also be activated on the 'Audio' tab and the Actions menu.

Record left channel

Background information:

When recording from the telephone Handset, the Pico receives two signals:

- 1) The signal of the microphone of the handset, this contains your own voice.

- 2) The signal of the speaker of the handset, this contains the voice of the remote caller, and often also your own voice.

The Pico software receives a stereo signal (left and right) from the Pico device. Normally the left channel is the microphone and the right channel is the speaker.

By default the Pico records only the right channel because this normally contains both the local and the remote voice. If this is not the case, change it by enabling the options:

- Add microphone channel
- Record left channel

3.3 Setup

3.3.1 Playback

- **Device:** The playback device that must be used for playback of recording, can be selected from the list. In most cases the sound card of the computer is used for playback.
- **Channel:** Also the channel of the Playback device must be selected. For the channel selection of the soundcard, usually the Wave or PC Speakers channel must be selected.
- **Volume:** The playback volume level.
- **Disable automatic starting of recordings during playback:** Enable this option when the Pico is used as playback device. This prevents that the software records the played back sound that is sent to the Pico.

3.3.2 Recording

A number of recording settings is common for all the connected devices. These settings are displayed here. Settings specific for a connected device, are displayed in Device options.

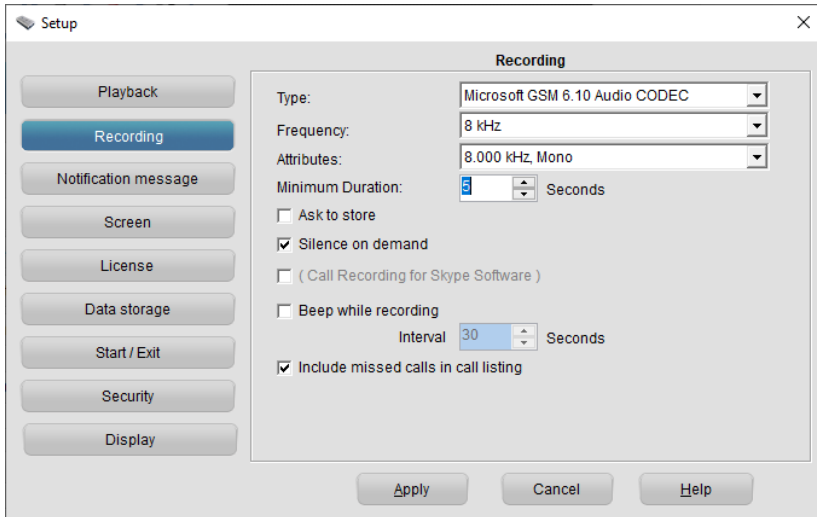

Type

Type displays all Codecs available. One of the Codecs of your PC is used to encode recordings. The Microsoft GSM Codec is present on most PC's. It offers a good balance between recording quality and required storage space. Therefore, if available, this Codec is selected as a standard.

Note: The Fraunhofer MPEG Codec (as available on Windows XP, Vista, 7, 8 and 10) should not be used when recording from multiple Pico devices, because this Codec supports only one recording at the time. The Microsoft GSM Codec does not have this limitation.

Frequency

Choose between a sampling frequency of 8 kHz (the default), or 16 kHz. A higher sampling frequency gives a higher quality recording, but uses more disk space.

Attributes

Attributes shows the various options of the selected Codec for the selected frequency. If it is empty, recording in the selected Codec at the selected frequency is not possible. Another Codec or frequency should be selected.

Minimum Duration

Minimum Duration refers to the minimum duration of a recording for it to be stored. A standard setting would be 5 seconds. Recordings shorter than the set Minimum duration will not be stored.

Ask to store

When "Ask to store" is enabled, you will have an option to cancel a recording when it is finished. The "Ask to store"-dialog has a field to add Notes to the recording.

Silence on Demand

When enabled, you can silence a part of a recording manually. You can start/stop the silencing with F6.

(Call Recording for Skype Software)

Note: This is a legacy option provided for compatibility with old installations. With the current version of Skype, this option no longer works.

By default this option is disabled. When it is enabled, and it is working, a button with the name "Uses Skype Software" is displayed in the List tab of the main screen.

Beep while recording

"Beep while recording" refers to the sounding of a beep during recording. In some countries, states, or areas the sounding of a beep during recording is required by law to notify the remote caller of the recording of the conversation.

- Check the checkbox to enable the beep while recording.
- The interval of the beep can be set below the checkbox.

Note It is possible the local caller hears the beep louder than it sounds on the remote side.

3.3.3 Notification message

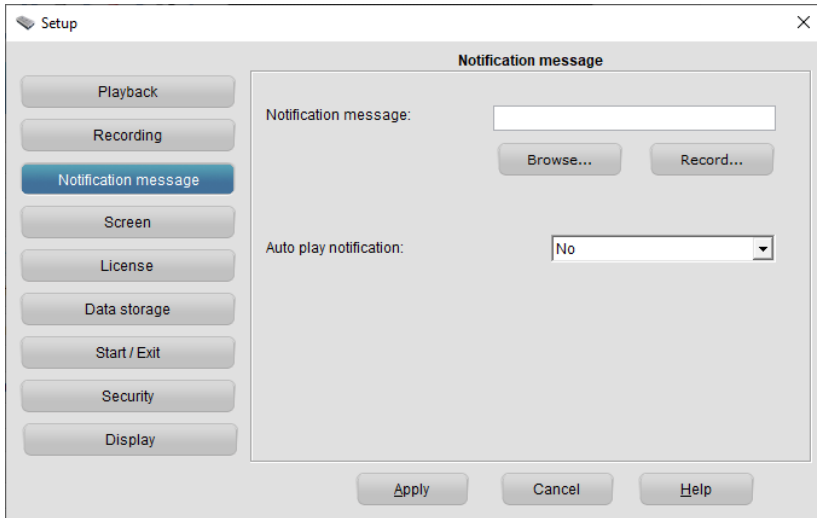

At the start of a recording a notification message can be played automatically, or manually when the **F8** key is pressed (PC) or using the button in the **Audio** tab.

To find a recorded notification message, follow these steps.

- Click on Browse
- Fill in the filename of the .wav audio file,

or Record a new message

- Click on Record

The following screen displays:

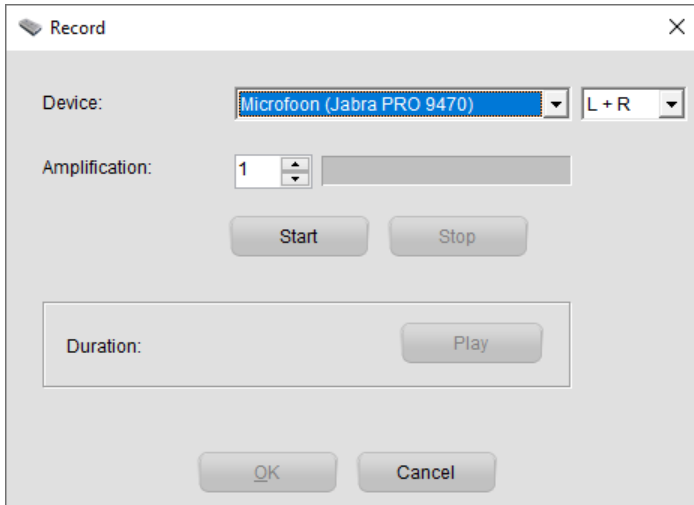

- Choose the **Device** to use for recording the notification message. On Windows XP, Vista, 7, 8 and other older Windows versions it may be necessary to select the recording channel using the Windows Mixer. Check if your PC has a built in microphone. If not, use an external microphone or the microphone in the telephone handset.

If you chose to use telephone's handset as the microphone there are two options:

- 1) The Pico is connected on the handset of the telephone
 - 2) The Pico is connected to the telephone line.
- Choose 'L' for option 1), the dialling tone will be filtered out.
 - Choose 'R' for option 2) the dialling tone, if present, will also be recorded. An external microphone will give a better result.
 - Choose 'L + R' when using an external microphone or the built in PC microphone.
 - Press the **Start** button to start recording the notification message.
 - Press **Stop** when you are finished
 - Press **OK** to save and use the newly recorded notification message.
 - It is recommended to check if the notification message has a good audio level for both calling parties when played back on the telephone line.

Auto play notification

This option determines if the notification message is played automatically when a recording starts.

- **No** - To playback the notification message, you have to press the Play notification button in the Audio tab or press F8.
- **For incoming Calls** - The notification message will automatically be started on incoming calls only.
- **Yes** - When a recording of any call starts, the notification message is played automatically.

Note The software can only detect an incoming call if the Pico is connected to the telephone line (i.e. when the Pico is connected to the telephone handset it can not detect an incoming call): When a recording starts and the software has detected it is an incoming call, the notification message is played automatically.

3.3.4 Screen

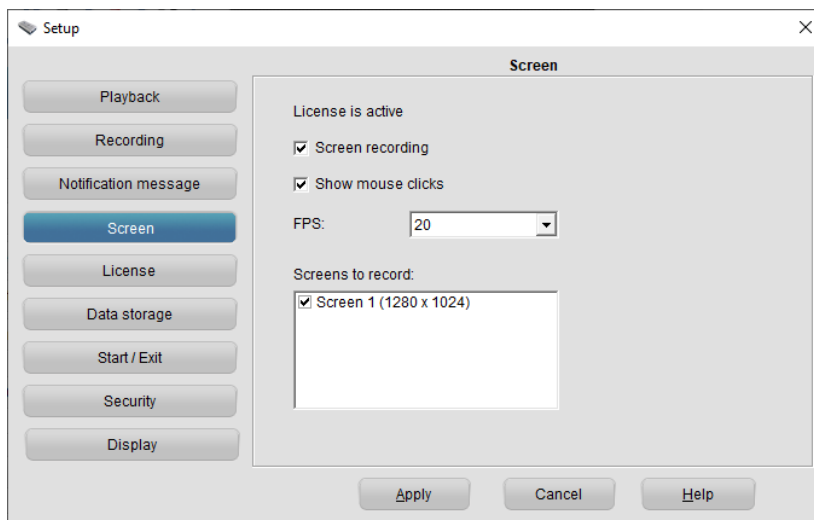

This section provides the options related to screen recording. It is available only if a screen recording license is activated (see License section).

Screen recording: If this option is enabled, a recording of what is visible on the screen will be made during a recording.

Show mouse clicks: Mouse clicks are visually shown in the screen recording using a colored circle.

FPS: The number of frames per second of the screen recording. A higher value gives a better quality video, but requires more CPU power and disk space.

Screens to record: If the PC has more than one monitor, choose here which monitors should be recorded. The screens to record should form one consecutive block.

The screen recording is merged with the audio into a MP4 file.

Screen recording does not operate well if it is also enabled in other Vidicode software (Oygo or Apresa Client software) on the same PC.

3.3.5 License

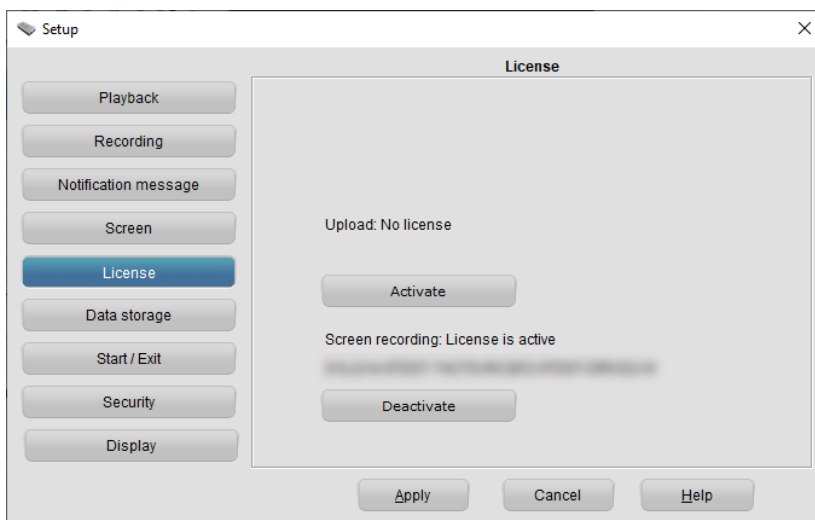

The licenses displayed here are for add-ons, and not needed for normal functionality.

Upload: If there is a license available for uploading to a Call Recorder Apresa (defined in the Data storage section).

Activate: Press this button to activate an upload license key. It starts with a V.

Deactivate: The license will be freed to be used at another PC.

Screen recording: The software displays if the screen recording feature is licensed. If so, then screen recording can be enabled and configured in the Screen section.

Activate: Press this button to activate a screen recording license key. It starts with an S.

Deactivate: The license will be freed to be used at another PC.

For activation and deactivation, internet access is needed. Licensing is performed by a separate program (PicoHelper.exe) that is run as administrator.

3.3.6 Data storage

The screenshot shows the 'Data storage' configuration window. The sidebar on the left has buttons for Playback, Recording, Notification message, Screen, License, Data storage (highlighted), Start / Exit, Security, and Display. The main panel is titled 'Data storage' and contains the following settings:

- Data Directory: C:\data\CRPico Archive\ (with a Browse... button)
- Log Files
- Directory structure: Year \ Month (dropdown menu)
- Automatic removal on program exit
365 Number of days until data are removed
- Export recordings to Call Recorder Apresa HTTPS
- IP Name or IP Address: [Empty text box]
- Username: [Empty text box]
- Password: [Empty text box]
- Delete after upload

Buttons at the bottom: Apply, Cancel, Help.

- **Data Directory:** In the data directory all call recordings are stored. Type the name of the directory, or press the Browse button to select a directory. The text %USR% will be replaced with the

Windows username. When there is already a database, it will be opened. Otherwise, a new call database will be created.

- **Log files:** When enabled, log files will be created in %appdata%\Vidicode\Pico. These log files can contain call details such as telephone numbers.
- **Directory structure:** Audio files are stored in subdirectories below the main data directory. Recordings can be stored in separate directories per year, month, day, and hour. Changing this setting only effects new recordings. To apply the setting to all existing recordings, create a new archive, and import the old archive into the new one.
- **Automatic removal on program exit:** When this option is enabled, calls that are a configurable number of days old or older, are deleted permanently from the archive. For example, if the Number of days until data are removed is 1, this means that all calls of yesterday and before are deleted automatically on program exit.
- **Export recordings to Call Recorder Apresa:** This will upload all the recordings in the archive to the Apresa using the account credentials. The account needs to have the Add recordings (API) permission. To use this feature, an upload license needs to be activated (see License section).
- **Delete after upload:** If a file has been successfully uploaded to Apresa, it will be deleted from the local Pico archive.

3.3.7 Start / Exit

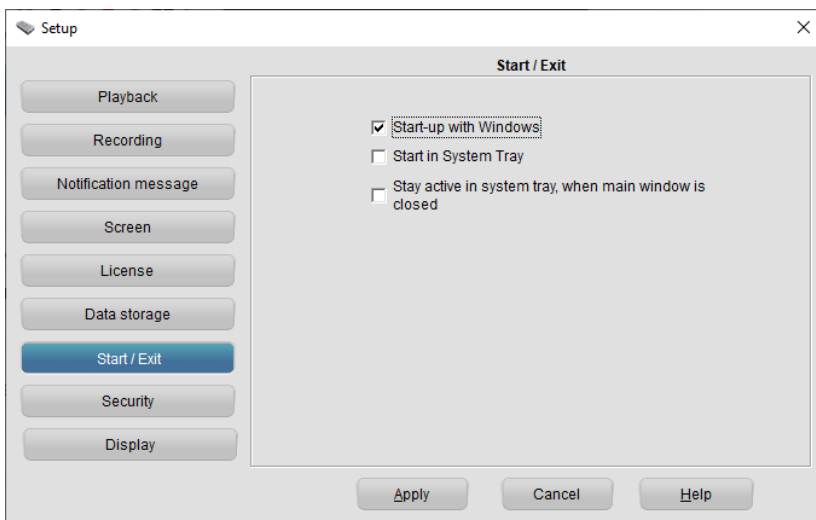

- **Start-up with Windows:** Start the program at logon in Windows.
- **Start-up in System Tray:** Start the application in the system tray (the lower right area in Windows).
- **Stay active in system tray, when main window is closed:** When this option is on, the software will move to the system tray and continue to record calls, when the main window is closed. To completely close the software, right-click on the system tray icon, and select Exit, or choose File, Exit from the main menu.

Because the Pico software needs to be running to store the recordings, it is advised to enable the option '**Start up with Windows**'. When the PC starts, it will automatically start the Pico software. The option 'Start in System tray' can be enabled if you do not want the software to be displayed on screen. The system tray on a PC is positioned at the lower right corner of the screen. On it all applications running in the background are visible as an icon.



It is possible to check both **Start up With Windows** and **In System Tray**. In that case the application will start at startup of your PC and will be moved to your system tray immediately.

When a recording is started, the application 'wakes up' and will show a red dot in the system tray. To get the application on screen when it is not recording:

- Click the Icon in the System tray

3.3.8 Security

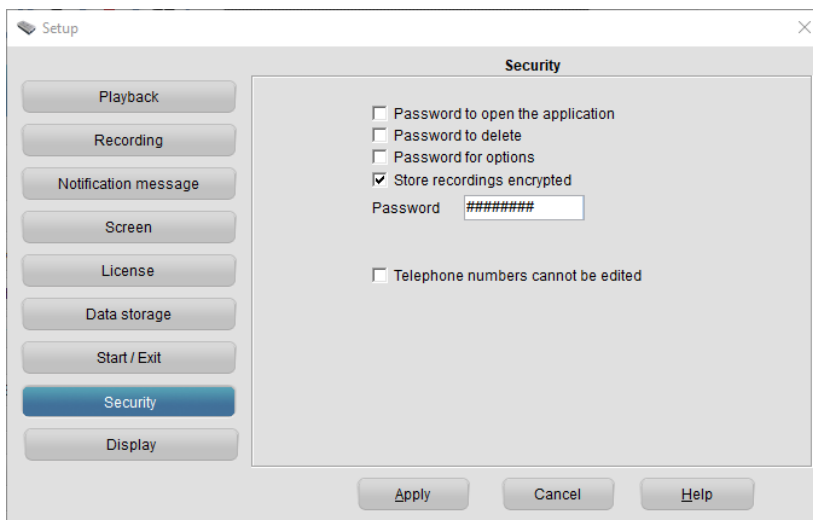

It is possible to protect the Pico application with a **password**. Deleting of recordings and settings of the program can be protected separately.

- Check the item you want to protect..
- Enter the password.
- Click 'Apply' to save the password.

Upon deleting a recording or entering the settings the user will be prompted to enter the password. Once entered the password remains active for 10 minutes.

3.3.9 Display

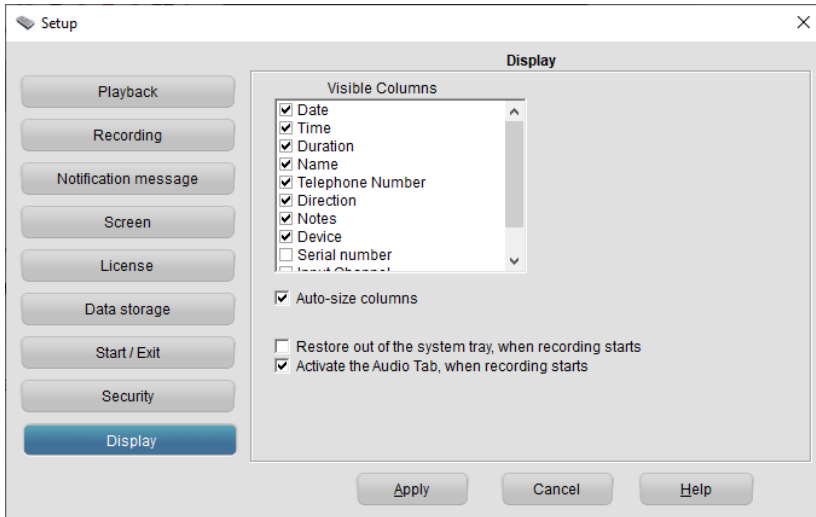

Visible columns: The recordings made with the Pico are stored in a database. The setting Visible Columns allows you to select which columns are displayed.

Auto size columns: this can be checked if you want the columns in the list view to adjust to the screen size automatically.

Restore out of the System tray when a recording starts: this should be checked if you want the application to be on the screen the moment a recording starts.

Activate Audio tab when recording starts: check this option if you want the application to automatically open the Audio tab the moment a recording starts. On the Audio tab you will find four buttons; Playback a file in a call', Playback a recording in a call', 'Play notification message' and 'Start monitoring'. See [Playback and Recording](#).

After finishing the settings

- Click Apply to save all changes.

4 Playback and recording

In this section the functions of the Playback and recording controls will be explained.

4.1 Normal playback

Select a recording and click the Play button to play it back, or double-click on a recording to play it, or right-click on it and select Play.

4.2 Playback in a call

To playback a recording or another audio file on the telephone line, audible for the other party.

Playback File in call

To playback a file on the telephone line, audible for the other party select the recording and:

- Open the **Audio** tab and
- Click the button 'Playback File in call'
- Select the file you want to play back by double clicking it.

Or

- Open the Actions menu and select the option 'Playback File in call'.
- Select the file you want to play back by double clicking it.

Playback Recording in call

To playback a recording on the telephone line, audible for the other party:

- Open the **Audio** tab and
- Click the button 'Playback recording in call'
- Select the file you want to play back and
- Double click it.

Or

- Open the Actions menu and select the option 'Playback recording in call'.
- Select the file you want to play back and
- Double click it.

Playback the notification message,

- Open the **Audio** tab and
- Click the button 'Play notification message'

Or

- Open the Actions menu and
 - Select the option 'Play notification message' .
- Or
- Press F8 on your keyboard

4.2.1 Playback and recording control display

To play back a recording:

- Select a specific recording in the archive
- Use the recorder keys to start playback.

or

- Double-click the recording

The recorder key functions resemble the ordinary recorder key functions.

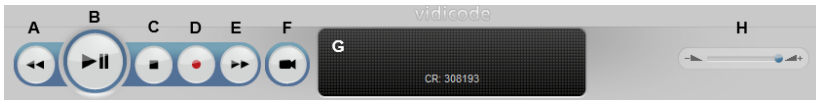

- A: Moves the playback position **backward**. Keep the key pressed for repeated and increased speed.
- B: **Start** or **pause** the playback of the currently selected recording.
- C: Stop the playback or recording.
- D: Start the **recording** for the currently selected recording device. This button is not visible when recording is automatic. When you have multiple Pico devices connected, you select another Pico device in the List tab.
- E: Moves the playback position **forward**. Keep the key pressed for repeated and increased speed.
- F: Is shown when a **screen recording** is available. It can be played back after it has been merged with the audio. Click the button to open the recording in the default player associated with MP4 files.
- G: **Information** about the current playback or recording is displayed here. Click on the progress bar to move to a specific position in the playback. When no playback is active, the name of the selected recording device is displayed (in this example: CR: 308193).
- H: Controls the playback **volume**.

4.2.2 Hotkeys

Key	Function
Ctrl + R	Start Recording
Ctrl + P or Spacebar	Play / Pause
Ctrl + L	Stop
Ctrl + U	Backward 30 sec.
Ctrl + I	Forward 30 sec.
Ctrl + J	Backward 2 sec.
Ctrl + K	Forward 2 sec.
F8	Play notification message
Ctrl + M	Monitoring
F6	Silencing

4.2.3 Using the Pico device as speaker output

When you do not have a soundcard, you can connect speakers directly to the Pico device, and select the Pico as playback device. Otherwise, using the Pico device as speaker output is not recommended. **Note:** When you use this configuration, audio that is played back might be audible for someone you are calling, even when Online playback is not used.

4.3 Automatic recording.

If you have chosen to automatically record all calls, (see § 3.3.2) it is still possible to stop a recording by pressing the Start/Stop button on the Pico device itself, or by clicking the Stop key on the recorder display.

4.4 Manual recording

If you have chosen to record manually or semi-automatic (see § 3.3.2) you have to activate the Pico to start recording. This can be done on the Pico itself, or with the recorder keys in the software.

To record a call manually:

- click the record key on the recorder display, or
- press the Start/Stop button on the Pico device itself.

4.4.1 Adding notes to a recording

Once a recording is made, it is possible to add additional information like the caller's name, number and some text.

- Select the recording you want to add the information to
- Right click.
- Choose 'Edit'

A dialog opens like the one shown below:

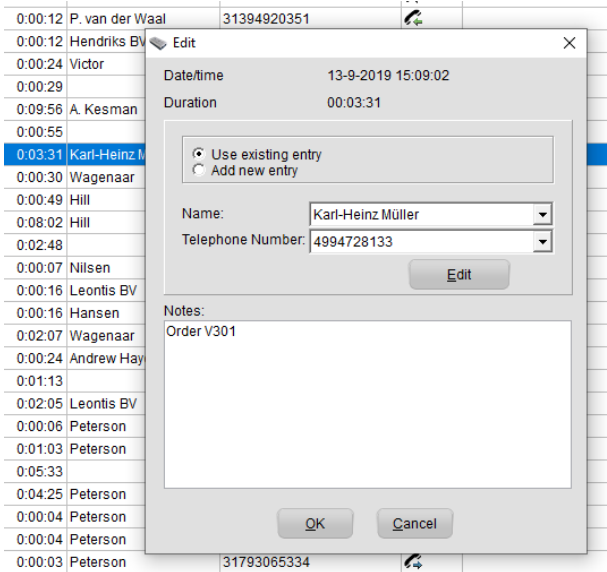

- Choose 'Add new entry' if the information you want to add is new.
- Enter the new information
- Choose 'Use existing entry' if the information (like name and number) you want to add already exist in the database.
- Select from the drop down
- Click OK when finished.

The new information appears in the list instantaneously

5 Layout of the software

When the software is started the program looks like this:

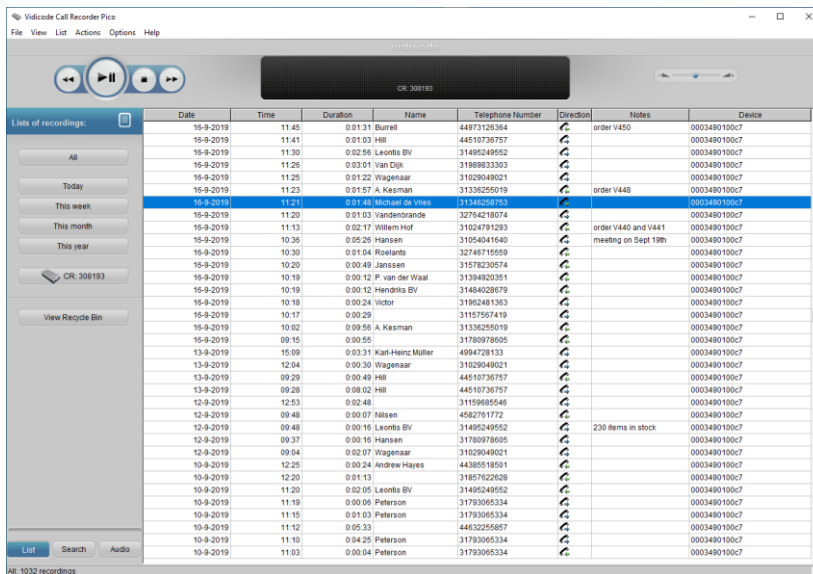

These are the items on the main screen:

- 🔍 The main Menu (at the top)
- 🔍 The playback and recording controls (at the top)
- 🔍 The buttons on the left
- 🔍 The three tabs: List, Search, Audio at the bottom left
- 🔍 The list of recordings (the large remaining area)

5.1 Main Menu

The main Menu gives access to File, View, List, Actions, Options and Help. In this chapter we will explain the menu options.

5.1.1 File

The menu item 'File' has three options. New, Open and Exit.

'New' will start a new call archive. This means that the database will be created in which the recordings will be stored. A dialogue opens in which you are asked to specify the location of the new database folder. The new Archive can be located on your PC or on the network.

'Open' allows you to open an existing archive (database). This can be an archive on the PC or on the network.

'Exit' closes the application.

5.1.2 View

The View menu has six options: 'Display the List Tab', 'Display the Search Tab's, 'Display the Audio Tab', 'Status Window', 'Status window: Only show recording devices' and 'Move to system tray' (see also §3.3.5).

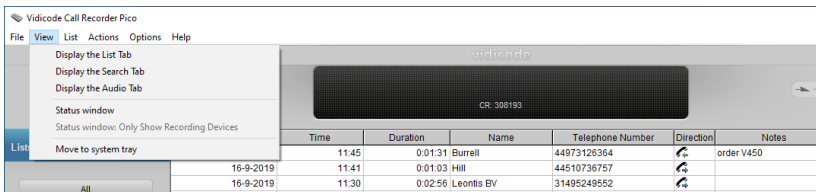

The 'Display...' options open the corresponding Tab to the left of the List view in the main screen.

The option 'Status Window' view puts a small status window on top of all other running applications in which the status of the connected device is shown.

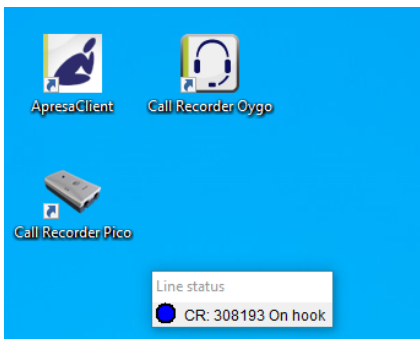

'Status window: Only show recording devices' is an additional option to Status Window, where the active window will only be visible when the Pico is recording.

Note: Clicking the 'dot' in the status window either starts or stops a recording.

The option 'Move to system tray' puts the active application in the system tray. The system tray on a PC is positioned at the lower right corner of the screen. On it all applications running in the background are visible as an icon.



The application is activated and back on screen the moment a recording starts, if you chose Automatic recording and checked the checkbox 'Restore out of system tray...' in Options – Setup – Display. If you have chosen the Manual recording option, you will have to bring the application back on screen as described below.

To retrieve the application from the System tray

- Click the Icon once

Or

- Right click the icon in the System tray and
- Choose 'Show'.

5.1.3 List

Recordings are saved to a database. In the software this database is referred to as Archive and shows as a list in the main screen.

The List Tab shows the buttons with which you can select from what predefined timeframe you want to see the recordings in the List view. ('All', 'Today', 'This week', 'This month', 'This year' and 'View Recycle Bin')

The actual list of recordings on the right changes with the selection you choose. To view a list of the complete database, click the All-button in the List tab.

Clicking the Column headers will sort the list by that column. i.e. if you want to see all outbound calls, click the column header 'Direction'. The calls will be grouped by direction 'in' or 'out'.

5.1.4 The Recycle Bin

The Recycle Bin resembles the Windows Recycle Bin. To put recordings in the Recycle Bin:

- Select recordings in the archive and
- delete the recordings with the Delete key on your keyboard.

A dialogue opens asking you to confirm the deleting.

or

- right click and choose 'Delete'.

A dialogue opens asking you to confirm the deleting.

- Use the SHIFT + Delete keys to permanently delete a recording without moving it to the recycle bin first.

The deleted recordings end up in the Recycle Bin. They are still in an archive. To Permanently delete the recordings:

- Press 'View Recycle Bin'
- Select the recordings you want to delete permanently
- Right click and choose 'Delete'.

A dialogue opens asking you to confirm the deleting

To permanently delete all recordings in the Recycle Bin

- Open the Actions menu
- Go to Recycle Bin
- Choose 'Empty'

Recordings can be restored to the database

To restore recordings:

- Click 'View Recycle Bin' in the List view
- Select one or more recordings you want to restore
- Right click
- Choose 'Restore'

Or

- Open the Actions menu
- Go to Recycle Bin
- Select one or more recordings you want to restore
- Choose 'Restore'

Or

- Open the Actions menu or click 'View Recycle Bin' in the List view
- Go to Recycle Bin
- Select one or more recordings you want to restore
- Right click
- Choose 'Restore'

5.1.5 Action

In the Action tab, you can Back up the recordings to CD, Import a back up from CD or from the network, Export actual recordings, Start / Stop the Monitor function, Play a notification message, Playback online and view Sub archives.

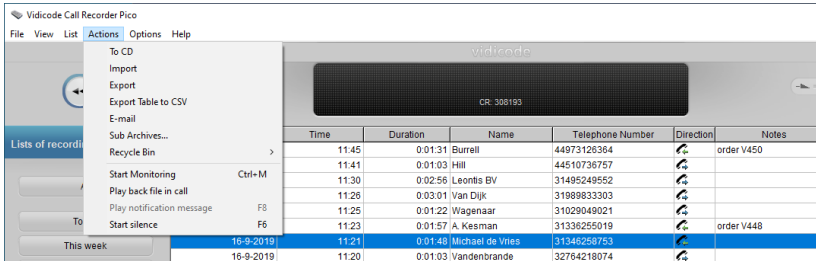

To CD

This function is used to back up an entire database or a selection of recordings on CD.

Note that you need to use a separate CD-writing application for actually writing the files to CD.

If you do not want to burn the entire database on CD

- Use the Search Tab to make a selection of the recordings you want to back up on CD.
- Go to the Actions menu and
- Choose To CD.

The following dialogue opens:

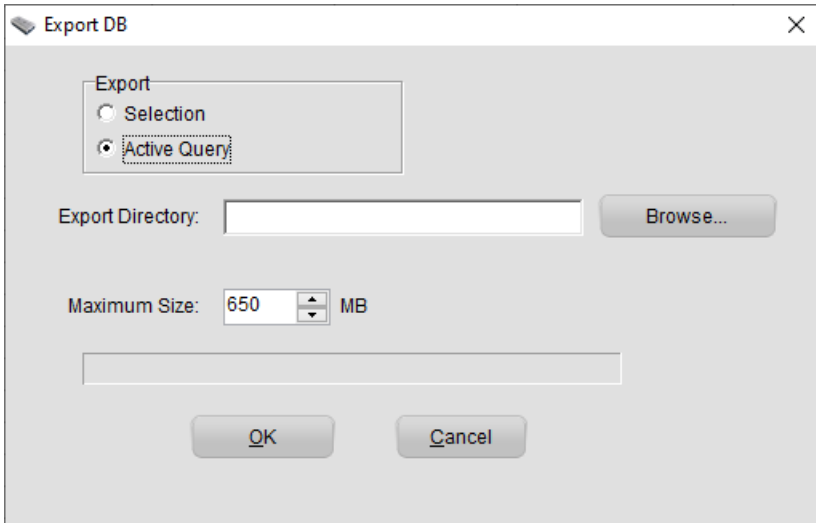

If you want to copy the **entire** database on CD:

- Click on the 'All' button of the List View. This will select all recordings.



- Then click on 'To CD' from Actions menu. The 'Export DB' dialog opens.

The options 'Selection' and 'Active Query' are greyed out. If you have made a selection of the database, for example 'This year', the radio button 'Selection' will be active.

- Browse to the location where you want to store the Export directory, using the 'Browse...' button, this can either be on the PC or on the network.
- Adjust the maximum size if needed.
- Click OK

If you back up more data than the 'maximum' size, multiple directories will be created as needed for multiple CD's.

Import

An existing database can be imported to the application. An existing database could be a database copied or exported from another Pico user. Select in the menu Actions, Import. Select the database that must be imported (recinfo.mdb). The recordings itself are also imported.

- Select the database and click OK to import it.

Export

Individual recordings and groups of recordings can be exported from the application. Select in the menu Actions, Export. The following dialog opens:

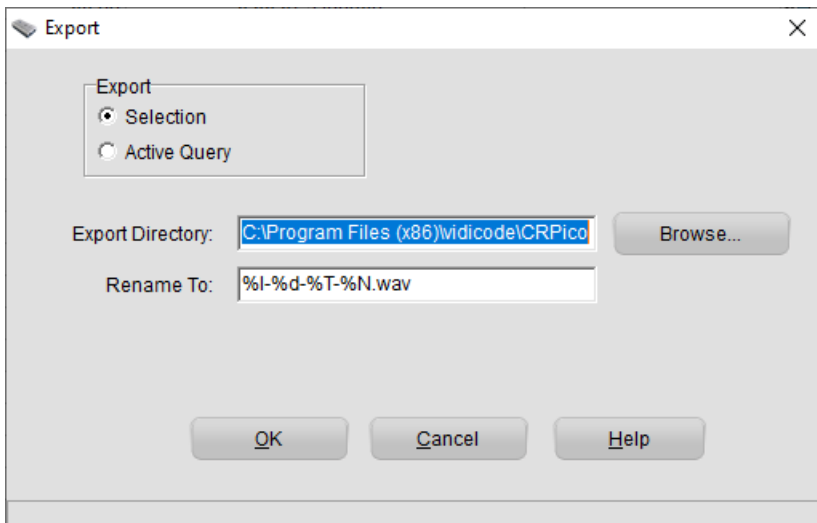

Select if you want to export the current selection or the whole query.

The Export directory is the location where the files will be stored. This location can be changed to your convenience.

Recording properties can be preserved in the filename of the recordings: You can add 'placeholders' in the filename that will be automatically filled in. These placeholders start with a percent sign (%) followed by a character. The following recording properties can be preserved in the filename of the recordings, by using placeholders:

%I is the number of the recording

- %D** is the date of the recording
- %T** is the time of the recording
- %X** is the duration of the recording
- %N** is the name associated with the recording
- %P** is the telephone number of the recording

- Press **OK** to execute the export.

E-mail

It is possible to send a single or a selection of recordings using email.

- First select the recording you want to send by email.

There are two ways to start an email.

- Open the Actions menu and choose 'e-mail'. An e-mail dialogue opens to which the recording is attached. The recording data is displayed in the email.
- Enter the receivers name and send.
- The second possibility is to select a recording, then right click and choose 'e-mail'.

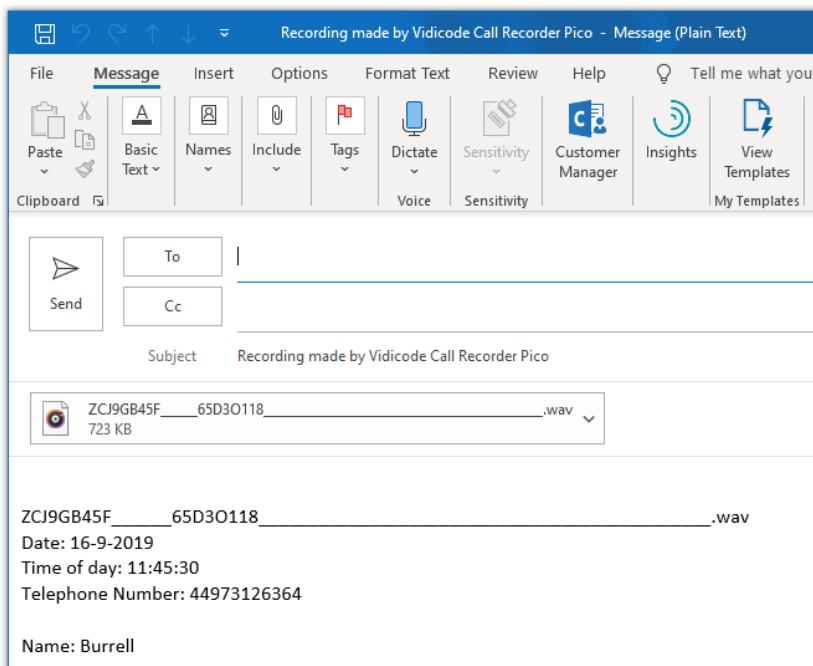

Sub archives

It is possible to combine separate Archives into one new Archive. The new Archive will be the 'Current Archive' the archives filled by the different Pico's are referred to as Sub Archive.

For example, a Supervisor may have access to a set of Pico Archives. These Archives should be on an accessible location for the supervisor like a network drive. The combined Archive is created by copying new recordings from the 'Sub Archives' to the 'Current Archive'.

To define which Sub Archives you want to access,

- Select Add, and browse to the location of the Sub Archive.
- Choose whether you want to copy the recordings manually, (click "Copy new recordings from Sub Archive" or automatically (check the "Auto Copy" box) .

To delete a Sub Archive,

- Select Delete.

New recordings will no longer be copied from the deleted Sub Archive,. Previously copied recordings stay in the Current Archive.

5.2 List, Search and Audio buttons

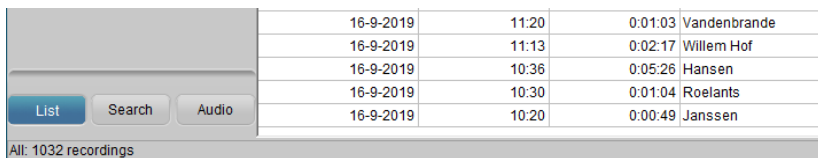

The screenshot shows a software interface with a table of recordings and a control panel. The control panel includes three buttons: 'List' (highlighted in blue), 'Search', and 'Audio'. Below the buttons, a status bar indicates 'All: 1032 recordings'. The table contains the following data:

16-9-2019	11:20	0:01:03	Vandenbrande
16-9-2019	11:13	0:02:17	Willem Hof
16-9-2019	10:36	0:05:26	Hansen
16-9-2019	10:30	0:01:04	Roelants
16-9-2019	10:20	0:00:49	Janssen

5.2.1 The List button

The List button displays the List view. To the left are the buttons with which a selection for the view can be made. To the right, the main screen, displays the (selection from) current archive.

5.2.2 The Search button

In the Search tab, you can define a Search. A Query based on a recording's date, week, time of day, duration, device, telephone number, name or notes.

- Click on the + in front of the properties you want to use in your query (one or more) and fill in the range or name, then click **Search**.

Save a query

Custom queries can be added to list for regular execution.

- Click on the property to expand it, fill in the required values or value range.
- Click Search to display the result of the search. An extra button has appeared on the menu to the left, the 'Save Search' button.
- Clicking this button will open a dialogue in which you can specify a name for the query. A shortcut to this query will be added to the List Tab.

The custom query can be removed by right clicking the button. Choose 'delete' to delete the query.

Date	Time	Duration	Name	Telephone Number	Direction	Notes
16-9-2019	11:45	0:01:31	Burrell	44973126364		order V450
16-9-2019	11:41	0:01:03	Hill	44510736757		
16-9-2019	11:30	0:02:56	Leontis BV	31495249552		
16-9-2019	11:26	0:03:01	Van Dijk	31989833303		
16-9-2019	11:25	0:01:22	Wagenaar	31029049021		
16-9-2019	11:23	0:01:57	A. Kesman	31336255019		order V448
16-9-2019	11:21	0:01:48	Michael de Vries	31346258753		
16-9-2019	11:20	0:01:03	Vandenbrande	32764218074		
16-9-2019	11:13	0:02:17	Willem Hof	31024791293		order V440 and V441
16-9-2019	10:36	0:05:26	Hansen	31054041640		meeting on Sept 19th
16-9-2019	10:30	0:01:04	Roelants	32746715659		
16-9-2019	10:20	0:00:49	Janssen	31579230574		
16-9-2019	10:19	0:00:12	P. van der Waal	31394920351		
16-9-2019	10:19	0:00:12	Hendriks BV	31484829879		
16-9-2019	10:18	0:00:24	Victor	31952481363		
16-9-2019	10:17	0:00:29		31157567419		
16-9-2019	10:02	0:09:56	A. Kesman	31336255019		
16-9-2019	09:15	0:00:55		31780978605		
13-9-2019	15:09	0:03:31	Karl-Heinz Müller	4994728133		
13-9-2019	12:04	0:00:30	Wagenaar	31029049021		
13-9-2019	09:29	0:00:49	Hill	44510736757		

5.2.3 The Audio button

The Audio button is a shortcut to the Audio options. It is possible to set the software up to open the Audio Tab on receiving a telephone call. The Audio tab has four options: Playback File in Call, Play back recording in call, Play notification message and Start Monitoring.

Playback File in call

To playback a file on the telephone line, audible for the other party select the recording and:

- Open the **Audio** tab and
- Click the button 'Playback File in call'

A dialogue opens with a tree view of all folders on your PC.

- Locate the file you want to play back
- Select the file you want to play back by double clicking it.

Or

- Open the Actions menu and select the option 'Playback File in call'.

A dialogue opens with a tree view of all folders on your PC.

- Locate the file you want to play back
- Select the file you want to play back by double clicking it.

Playback Recording in call

To playback a recording on the telephone line, audible for the other party:

- Open the **Audio** tab and
- Click the button 'Playback recording in call
- Select the file you want to play back by double clicking it.

Or

- Open the Actions menu and select the option 'Playback recording in call '.
- Select the file you want to play back by double clicking it.

Play notification message

To playback the notification message,

- Open the **Audio** tab and
- Click the button 'Play notification message'

Or open the Actions menu and select the option 'Play notification message'.

Start Monitoring

This option allows for supervisors in an other room to listen in on the conversation that is taking place. As the sound is not real time it is not advised to enable this option when the telephone and the PC are in the same room. This option can also be activated on the 'Audio' tab and the Actions menu.

6 Problem solving

6.1 Restoring your soundcard

The hardware installation of a Pico will make this device the preferred sound device of your computer because it is the last device added to your configuration. If you have a soundcard in your system and you use it for other applications it is advised to restore the original sound device as preferred device again. This is done as follows:

- Click Windows **Start** in the lower left corner on the taskbar in your computer screen
- Select the "Control Panel".
- Select "Multimedia" or "Sound and Multimedia" / "Sound, speech and Audio Devices"
- Select the **Audio** tab.
- Select your preferred device for playing and recording.

WARNING: If you do not restore your soundcard as preferred audio device there is a chance the sound of games and other applications will no longer work. If you change the USB-port the Pico is plugged in to, you may need to repeat restoring your soundcard.

6.2 Software does not detect the Pico hardware

If the Pico software recognizes a Pico device, the Pico will show up in the drop-down list in the Devices window. You can reach the Devices window via Options menu of the Pico software.

- Windows 10 introduced new "Microphone privacy settings", which can be found in the Settings app of Windows. In this screen, it is needed that "Allow apps to access your microphone" is enabled, to allow CR Pico to record audio. See the picture below.

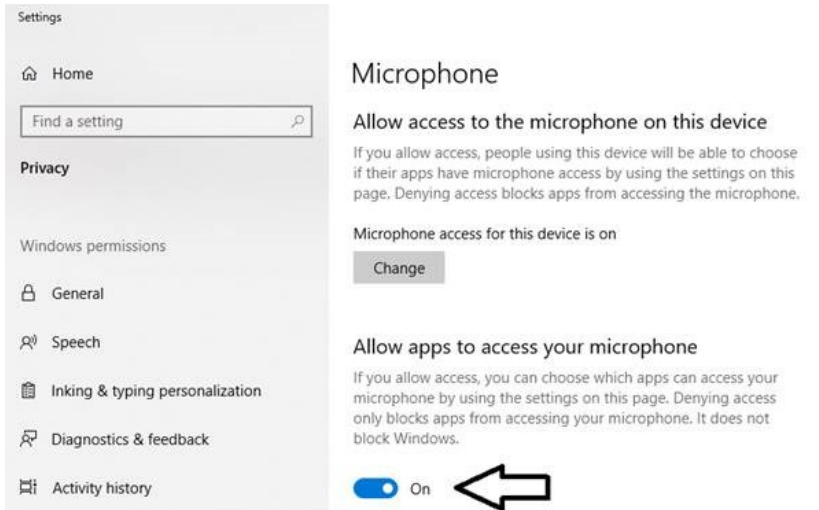

- In some cases the CR Pico Line device is not available. To correct this, set it as default recording device. See the picture below.

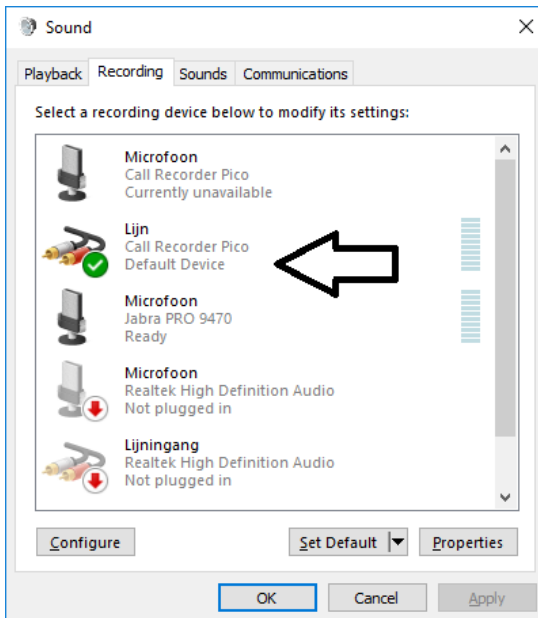

- The CR Pico playback device (“speakers”) should have its volume set to max and not be muted.
- Kaspersky anti-virus can block a program to access an audio device. Allow the Pico software to access the Pico device. See [Kaspersky blocks access to the audio device](#) in this document.
- If the names of the CR Pico devices are too long, this problem occurs. A name less than 20 characters long should be ok, which is normally what Windows assigns by default. To edit the name, in the sound screen, edit the properties of the device and fill in a shorter name.

6.3 Kaspersky blocks access to the audio device

How to allow the Vidicode Call Recorder Pico to access audio devices in Kaspersky Total Security:

- Open the main application window of Kaspersky Total Security.
- In the lower part of the main window, click the **More Tools** button to open the Tools window.
- Go to the **Manage applications** section.
- Click the **Application Control** link to open the Application Control window.
- Click the **Manage applications** link to open the Manage applications window.
- In the list, select the application “CRPico.exe”. Double-click the application to open the **Application rules** window.
- In the **Application rules** window, go to the **Rights** tab.
- In the list of rights categories, select **Operating system modification** → **Suspicious modifications in the operating system** → **Access sound recording devices**.
- In the **Action column**, click the icon and select the menu item **Allow**, to allow CRPico.exe to receive the audio stream.
- Click the Save button.

6.4 Windows does not detect the Pico hardware

- The CR Pico consists of both audio devices and a HID device, all of these need to be recognized (shown in Device Manager). If this is not the case, there could be USB / hardware / cabling problem.

If the USB port is the problem, connecting the Pico to another USB port can solve this. Replace the USB-cable to see if the cable is the problem.

6.5 Problems setting the Start/Stop level

The following symptoms could occur when the Start/Stop level is not set properly.

When the level is set too low (to the left) it is possible that recording starts too early, or the Pico is recording all the time, resulting in empty recordings.

When the level is set too high (to the right) recording will start too late resulting in calls not being recorded or calls being split up over two or more recordings.

6.6 Problems setting the Stop time

The following symptoms could occur when the Stop time is not set properly.

When the Stop time is set too low, recordings of calls are cut off prematurely, or calls are being split over two or more recordings.

When the Stop time is set too high, there is a chance that more calls, especially calls shortly after each other, are recorded as one recording.

6.7 Problem with playback volume slider

If you move the volume slider and nothing happens, it is possible the software chose the wrong channel for playback. This could occur if the name of the channel on your soundcard is not the same as the name of the channel chosen by the software.

- Go to **Options – Devices** and change the “**Recording Channel**”.
- Choose a channel with a name similar to **WAVE** or **Speaker** or **Master Volume**

6.8 Problems with distorted audio

If you have a problem with your phone not working properly or the sound is distorted and you connected the Pico to the handset of the telephone, chances are the wiring of your telephone is not standard. In that case, set the 'I II' switch to 'II'.

6.9 Problems with high Start level

(handset or headset connection only)

In some digital telephones the handset is not switched off or muted after hanging up the telephone. When **ON** the handset microphone might pick-up surrounding noises. As a result, the Pico would record all the time.

If this is the case, the only way to set up the Pico is to start a recording manually either from the software or on the actual Pico. This problem also occurs with some headsets.

6.10 Problems with automatic start / stop

In some cases, only when you have a cordless telephone with its own power supply AND the Pico is connected to the telephone line, you may have a problem with starting or stopping a recording, although all device settings are made properly.

The symptoms are: The recording starts in Automatic mode, but does not stop (immediately) when the telephone is 'on hook' again. Or, in automatic mode (on/off hook only) and in semi-automatic mode, the Pico does not start recording when the telephone is 'off hook'

If this occurs, it may be a hardware problem. The Pico probably does not detect the telephone is on or off hook, because the line voltage detection level is too low. The line voltage detection level can be increased by removing the jumper from within the Pico.

This is what you should do:



Disconnect the Pico from the Telephone (line) and from the PC.
You'll need a pair of tweezers (preferable plastic).

After that, follow the instructions below.

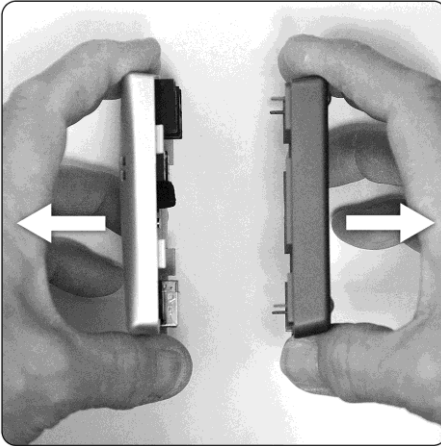

1 - Carefully open the Pico by disconnecting the blue and the gray parts, this should be easy.

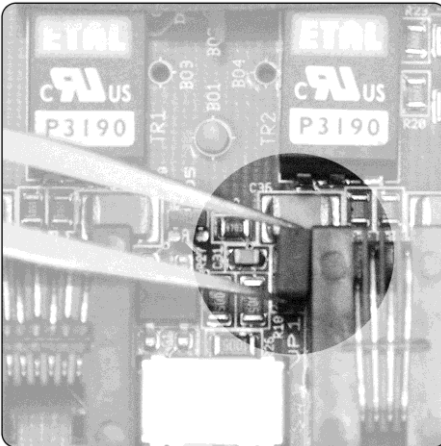

2 - Now locate the jumper, (a small black plastic square), there is only one jumper inside the Pico. It is located against the side of the smaller of the two telephone line connectors and it is marked JP1

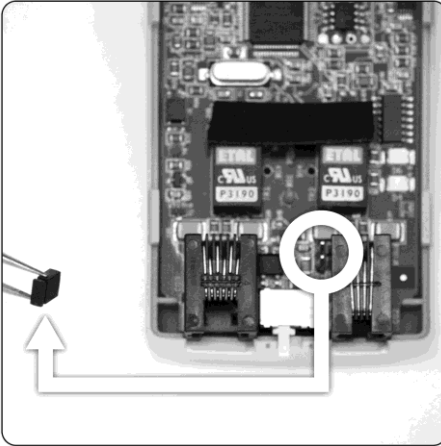

3 - Remove the jumper from the pins.

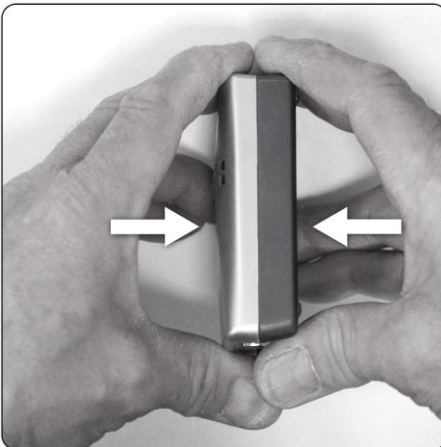

4 - Close the Pico's case.

Connect and re-install the Pico and try if it is working properly now. It should now be able to detect whether the telephone is on or off hook.

6.11 Problems with PC start up after connecting Pico

If the Pico is connected to the PC via a USB-hub, even a USB-hub with its own power supply, **and** the PC does not start up after you have connected the Pico, we advise you to connect the Pico directly on the PC's USB port and start up the PC again. The problem should now be solved.

6.12 Detection of Telephone Numbers

The detection of telephone numbers (caller ID) is only possible on an analog telephone line on which the number is communicated using DTMF or FSK. It is not available for digital phones.

For the detection of telephone numbers to work, the software must be told that the Pico is connected to the Phone Line and not the Phone Handset. To adjust the settings, go to Devices from the Options menu and click on the Basic button. On this tab, choose: **The device is connected to the Phone Line.**

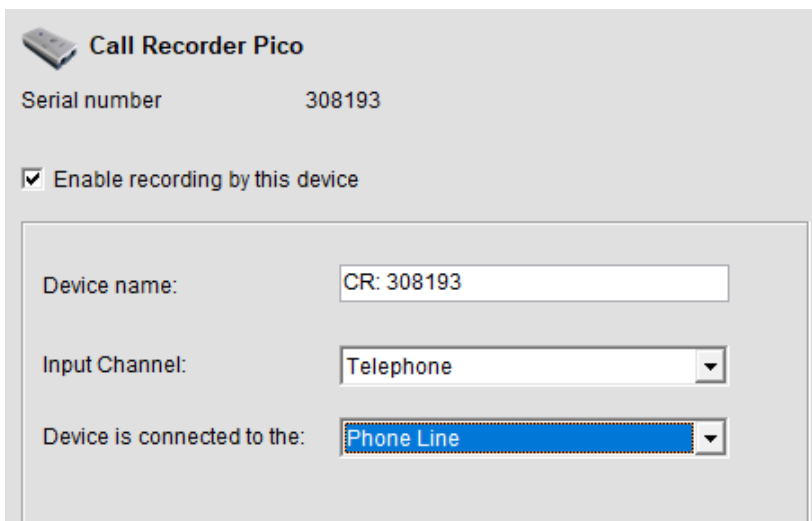

Call Recorder Pico

Serial number 308193

Enable recording by this device

Device name: CR: 308193

Input Channel: Telephone

Device is connected to: Phone Line

If still no number is detected for incoming calls, the volume might be too high, causing clipping of the audio. Go to the Options menu and choose

Devices. Click on the Volume tab and decrease the volume by moving the volume slider to the left.



7 Software Update Online

The Pico software has the ability to check for software updates and to download them from the internet.

- Choose **Help** in the menu
- Select Check for update.
- Click Check Update

The fixes of the last update are displayed.

- Press **Download** to start downloading the update.
- When downloading is finished the new version will be installed.

For this function an Internet connection is required.

8 Acknowledgements

8.1 Privacy

When recording telephone conversations the privacy of your conversation partner must be considered.

In some countries there is an obligation to notify your conversation partner of the recording. Check your national legal obligations on this and other issues concerning the use of the Call Recorder.

In the United States, the Federal government requires that only one person involved in a conversation must know the call is being recorded. However, each state has legislation. The vast majority of states have laws complying with the Federal "one party" requirement. A few states do require that both parties are informed the call is being recorded.

The Call Recorder can comply with either one party or two party requirements. One party simply means the person with the Pico knows the call is being recorded. Compliance is made with two party requirements by either playing the beep while recording, or by playing an announcement at the beginning of the call.

Vidicode is not a source of official interpretation of laws of any country or state, and shall not be construed as a source for making decisions whether to provide notification or not. Vidicode assumes no liability regarding incorrect notification of call recording.

8.2 Liability

Correct functioning of the Pico cannot be guaranteed under all conditions and thus we do not accept any liability for loss of information or other damages due to the use of the Call Recorder Pico.

Appendix A – Automation interface

The Call Recorder Pico has an 'automation interface' with which developers of for instance Call centre software can control the Pico's software. This means that Start and Stop of recordings and Archive location can be controlled by external software.

The ActiveX automation server is called **SCR.Recording**. The following functions are available:

- **SetPreStartPeriod(Seconds : int)**
Add a number of seconds before the StartRecording signal to the recording when available. Maximum is 30 seconds.
- **StartRecording(DeviceId : int, FileName : string)**
DeviceId 1 is the first enabled Pico device, FileName is the file where the recording must be stored.
- **StopRecording(DeviceId : int)**
Stops the recording.
- **State(DeviceId : int)**
State returns:
0 when recording not active
1 when recording is active
-1 when device-id is invalid
- **LastDuration(DeviceId : int)**
Returns the duration of the last recording.

One recording device must be enabled in the Pico software and set to *manual* recording (not automatic) in the Devices options.

Example Visual Basic Script: (example.vbs)

```
sub TestPico()  
    ' When the Pico software is not started, it will be started.  
    set obj = WScript.CreateObject("SCR.Recording")  
  
    ' wait until user clicks Ok  
    ' State returns 0 when recording not active,  
    '         and 1 when recording is active  
    '         and -1 when device-id is invalid  
    msgbox "Pico is started. State: " & obj.State(1)  
  
    ' Add a number of seconds before the StartRecording signal  
    ' to the recording when available.  
    ' Maximum is 30 seconds.  
    obj.SetPreStartPeriod 30  
  
    ' Start recording  
    ' The first parameter is the device id  
    ' 1 = the first enabled recording device  
    obj.StartRecording 1, "C:\test_pico_output.wav"  
  
    ' wait until user clicks Ok  
    msgbox "Pico started recording. State " & obj.State(1)  
  
    ' Stop the recording  
    obj.StopRecording 1  
  
    ' The output file is now created  
    ' (even if the duration is shorter than the minimum duration  
specified  
    ' in the settings)  
  
    ' wait until user clicks Ok  
    msgbox "Pico stopped recording. State " & obj.State(1)  
  
    ' Retrieve the duration of the last recording  
    msgbox "Duration: " & obj.LastDuration(1) & " seconds"  
  
    ' When the Pico was started by the script, it is closed at this point  
end sub  
  
' call sub TestPico (see above)  
TestPico()  
  
' wait until user clicks Ok  
msgbox "exitina"
```

INDEX

A

Acknowledgements, 49
analogue telephone line, 8
archives, 32, 36
Automatic Gain Control, 18
Automatic recording, 17

C

Control Panel, 40

D

Device is connected, 16
device settings, 15
Duration, 20

E

E-mail, 35
Export, 32, 34

F

Frequency, 19

G

Getting started, 8

I

Icon, 15
Import, 32, 34
Internet, 48
Introduction, 7

L

Layout, 29
Liability, 49

M

Multimedia, 40

N

notes, 27
Notification, 21

P

password, 23
Pico, 8
Playback, 19, 25, 26, 27, 38, 39
Privacy, 49
protect, 23

R

Record from handset, 8, 9, 10
recorder keys, 26, 27
Recycle Bin, 31

S

Search, 37
Security, 23
Skype, 20
software installation, 11
Software Update Online, 48
sort, 31
soundcard, 40
Start/Stop, 43
Station name, 15

V

Voice activated, 17